



Master Strategic Leadership Plan

**2003-2008, and now
extended through 2013**

February of 2009 Update

**South King Fire and Rescue
31617 1st Avenue South
Federal Way, WA 98003
Phone: 253-839-6234
e-mail: info@southkingfire.org
www.southkingfire.org**

Adopted November 21st, 2002

TABLE OF CONTENTS

Table of Contents.....	2
Mission Statement, Vision Statement and Guiding Principles.....	3
Overview.....	5
Strategic Leadership Goals.....	6
Strategic Leadership Teams.....	7
Strategic Objectives, Probable Courses of Action, and Action Steps.....	8
Human Resource Goals and Action Items.....	10
Integrated Operations Goals and Action Items.....	15
Leadership Goals and Action Items.....	22
Community Goals and Action Items.....	26
Financial Goals and Action Items.....	33
Master Strategic Leadership Team Work Product (2003-2008).....	38
2007 Work Product and Top 10 List for 2007/2008.....	65
Project Team Assignments for 2008.....	68
Vision for the Future/Bond Issue Work Groups for 2008-2009.....	76
2009 Work Product, SWOTT and Top 10 List for 2009 – 2010.....	88

MISSION STATEMENT

WE HELP PEOPLE by responding with professional Fire Department services.

VISION STATEMENT

Be a Regional Leader in providing quality Fire Department services.

GUIDING PRINCIPLES

- **Meet Or Exceed The Customer's Needs**
- **Perform Your Duties Safely**
- **Keep It Clean and Professional**
- **Be Honest, Respectful, Loyal and Communicate Openly**
- **Help Each Other Succeed**
- **Continually Improve Your Skills**
- **Be Prepared To Perform**
- **Help To Provide Achievable Solutions**
- **Never Walk Past A Mistake**
- **Be Responsible For Your Actions**

- **Finish What You Start**
- **Take Care Of Each Other, Treat Each Other With Respect**
- **Follow The Rules**
- **Serve With Pride**
- **Hold ourselves and each other accountable**
- **Support These Guiding Principles**

The “Mission” and “Vision” Statements were developed to establish the overall guiding principle for the entire organization. The “Guiding Principles” were established to further clarify the expectations that each and every employee has of one another within South King Fire and Rescue.

These were all originally developed during retreats held in 1997 with members from throughout the organization. They were reviewed and reaffirmed during the process to establish the 2003 through 2008 Strategic Leadership Plan. The plan was then updated during 2007/2008 to reflect the next five (5) year period, covering up through 2013, and thus ensuring that the Strategic Leadership Plan is a living document.

Overview

This document contains an update to the “living” South King Fire and Rescue Strategic Leadership Plan. Goals and objectives have been evaluated by the Master Strategic Leadership Planning Team, with successes noted; goals and objectives for the future established; and teams to work on the goals/objectives appointed together with timelines for success.

The Master Strategic Leadership Planning Team, together with the members of the entire organization, are keeping this Strategic Leadership Plan alive and moving forward. It has provided guidance when making financial and operational decisions, and will continue to be reviewed and updated on an ongoing basis.

Strategic Leadership Goals

The following establishes the “Strategic Leadership Goals” that were established for South King Fire and Rescue via the Master Strategic Leadership Planning team process:

1. We maximize quality training while maintaining high level emergency response capabilities.
2. We have well maintained programs to promote health, wellness, and welfare for all employees.
3. We have an internal human resource mechanism for selecting, developing, and valuing employees.
4. We have communities that are educated, aware and supportive of our services.
5. We have stable funding that allows for growth and supports our mission.
6. We excel in providing consistent, safe, and professional emergency services for our community.
7. We provide strong and competent leadership that values motivation, confidence and job satisfaction.
8. We are a leading force in community cultural knowledge and the positive integration of diversity within our organization.
9. We provide awareness and prevention education to the community to reduce risks to life and property.

Strategic Leadership Teams

Once the Strategic Leadership Goals were established, the Master Strategic Planning Team then divided up into sub-groups to further research and refine the goals with input from all departmental members. Their work was then redefined into Strategic Goals, which are visionary and far reaching; operational goals, which are task oriented and considered the “meat and potatoes” of the plan; and those issues which will potentially be taken into consideration in the future, or as things change within the course of time.

The team members for this portion of the planning process consisted of:

Human Resources Team:

Donna Conner
Mary Stevens
Wendy Chinn
Vic Pennington
Kirsti Weaver
Alex Charoni
Anthony John

Core/Overhead Team:

Commissioner Hershey
Commissioner Gates
Commissioner Harris
Chief Church
Assistant Chief Plumlee
Ryan Herrera, Local #2024

Integrated Operations Team:

Mike Knorr
Pat Soper
Vic Pennington
Steve Trackwell
Kevin Body
Gregg Bordner
Chris Murphy
Nick Spaeder
Shane Smith
Ed Plumlee
Joel Barrett
Mike D. Lawson
Joe Ganem
Todd Williams
Travis McKenney

Community Team:

Gordie Olson
Jerry Clos
Kendra Kay
Kirsti Weaver
Donna Conner
Chris Ingham
Kevin Crossen
Ron Biesold

Leadership Team:

Ed Plumlee
Vic Pennington
Chuck Kahler
Bob Stinnett
Alex Charoni
Jeff Bellinghausen
Todd Williams
Anthony John
Rick Chaney
Dave Mataftin
Ryan Herrera
Kevin Crossen
Roy Smith

Finance Team:

Al Church
David Lawson
Steve Trackwell
Joel Barrett
Lauri Perry
Pat Soper
Scott Ervin

Strategic Objectives, Probable Courses of Action, Additional Issues/Future Considerations and Action Steps

This section of the Strategic Leadership Plan establishes the “meat and potatoes” for South King Fire and Rescue. It incorporates the vision and future direction for the department in the following areas:

- **Human Resources**
- **Integrated Operations**
- **Leadership**
- **Community**
- **Financial**

Each main topic area, such as human resources, has one or two Strategic Leadership Goals which were used to establish the broad vision of the department’s future as a starting point. From there, the planning teams established a Vision of the future and a Mission Statement related to the Strategic Leadership Goals. These helped set the direction for research and input related to meeting the goals and vision of the future.

The next step in the process was to establish Strategic Objectives, Probable Courses of Action, Additional Issues/Future Considerations and Action Steps to support the broader Strategic Leadership Goals. Many of the Strategic Objectives and Probable Courses of Action are mutually supported across the teams.

- **Strategic Objectives:** These are objectives which support the vision of the future. They are more defined than the very broad Strategic Leadership Goals, but still are a vision of where the department wants to be without a great deal of specificity.
- **Successes:** These are objectives which have been completed during the previous year, but which must be maintained and/or augmented for future year successes.
- **Probable Courses of Action:** These are the specific and measurable items identified by the planning teams as helping the department to meet the goals of the future vision. These are the true “meat and potatoes” of where the department wants to be in the future.
- **Additional Issues/Future Considerations:** These are issues which the planning teams identified as things which may be

considered in the future, but might not be realistically attained within the next 5-6 years.

- **Action Steps:** These are the initial steps to take towards helping to meet the goals and action items established by each planning team. These action steps are living items and subject to change annually.

Human Resources

The goals associated with human resources reflect South King Fire and Rescue's commitment to our employees, their health and wellness, and their future development.

Goal #2: We have well maintained programs to promote health, wellness, and welfare for all employees.

Goal #3: We have an internal human resource mechanism for selecting, developing, and valuing employees.

Vision: South King Fire and Rescue has a highly valued workforce with a focus on employee wellness, diversity, and respect.

Mission: Our mission is to develop our work environment based on the promotion of health and respect for the differences in others.

I. Strategic Objectives

- a. South King Fire and Rescue shall make fitness, health and wellness, a priority each day.
- b. South King Fire and Rescue shall promote the best candidates into open positions.
- c. South King Fire and Rescue shall strive to improve communications throughout the entire organization. (Note: This objective has an action step under the Leadership section).
- d. South King Fire and Rescue shall strive to meet the goals established within the Strategic Leadership Plan.

II. Successes which must be maintained

- a. Finalize and adopt the Strategic Leadership Plan.
- b. The daily schedule for all personnel shall be streamlined to allow for the necessary work to be completed, without undue stress or burnout of personnel.
- c. The Strategic Leadership Plan shall be reviewed on an ongoing basis, with annual updates intended to meet changing community and departmental needs.

- d. The Strategic Leadership Plan shall have a reporting mechanism developed to report back on measurable outcomes associated with the established goals and action items.
- e. The Assistant Chief of Operations shall head up a team that will formalize the daily schedule to incorporate all daily tasks.
- f. Management shall set the example by prioritizing time for physical exercise or health and wellness education.
- g. Education shall be prioritized and provided to each member of this department to assist them in establishing a fitness, health and wellness regimen.
- h. The department will strive to meet or exceed the provisions contained within the “IAFF/IAFC Wellness Fitness Initiative” for all employees.
- i. An improved system of personnel evaluations/assessments will be developed and implemented (or eliminated altogether).
- j. All work stations should be monitored and updated as needed to ensure compliance with ergonomic requirements.
- k. Physical fitness equipment and programming should continually be upgraded and available to meet the needs of all department employees.
- l. A process shall be developed to assist in the proposed integration of KCFPD #26 and Federal Way Fire personnel into a new “South King Fire and Rescue” merged fire department, including their involvement in the Strategic Leadership Planning processes.
- j. Stations #62 and #64 need to be evaluated related to space considerations for physical fitness equipment tied into the “wellness/fitness” initiative in place within the department.

III. Probable Courses of Action

- a. A system to allow upper management to communicate more with line personnel, and visa versa, will be established.
This has been initiated; to be followed up on in 2008.
- b. The Administration and Labor should work together in analyzing alternative health care options for all personnel. This should include an analysis of means to cut costs without cutting benefits; should include a look at HRA's, HSA's, and flexible accounts; and should include controlled enrollment.
This has been initiated; to be followed up on in 2008.
- c. A process for succession planning and mentoring shall be developed to enhance the development of our personnel. This shall include:
 1. A system to track the ongoing educational goals, and education itself, of our personnel related to their professional development with an inherent goal of providing the employees assistance with their ongoing development.
 2. A system to track our employee's skills, a "skills inventory", which would provide the department with the ability to tap into these skills to further develop other department members.
This has been initiated; to be followed up on in 2008.
- d. An improved process of targeting, recruiting and potentially hiring a more diverse workforce shall be developed and implemented. This could include a "Prospective Firefighter Orientation Day", coordination with the military's transition assistance team, as well as a South King Fire and Rescue "Recruitment Team".
This has been initiated; to be followed up on in 2008.
- e. The current performance assessment/evaluation system should be revisited to ensure it is meeting the needs of the department and our personnel's growth.
This has been initiated; to be followed up on in 2008.
- f. Stations #62, 64 and 26 need to be evaluated related to space considerations for physical fitness equipment tied into the "wellness/fitness" initiative in place within the department. Other options should be considered for physical training, including the potential use of the Highline Community College weight room for north end

station personnel, and the surplus of certain pieces of physical training equipment not found to be useful and taking up needed space.

This has been initiated; to be followed up on in 2008.

- g. Ensure that the best qualified candidates are hired for any and all positions within the department, with a strong desire to improve the overall diversity within the employed members of South King Fire & Rescue.

This has been initiated; requires ongoing follow-up.

- h. A program shall be developed to assist in educating our personnel regarding the clientele they serve within the community of different ethnic backgrounds. This program shall focus on diversity (i.e. the diverse make up of our service area) and the social aspects of our different ethnic backgrounds and customs. An implicit goal will be to partner with community members, and to bring in a diverse set of instructors to present and share their information.

Nothing done to date.

IV. Action Steps

These are the next steps in the process of following through on the Strategic Goals and Action items. These shall be revisited and updated annually:

#1: Follow through on our current system allowing upper management to communicate more with line personnel, and visa versa. The system should be monitored and augmented as necessary.

#2: The Administration and Labor should work together in analyzing alternative health care options for all personnel.

Note: This was initiated in 2008 with the work on an HRA. To be followed up on in 2009 and beyond.

#3: A complete “prevention and rehabilitation system” shall be developed by the HR Manager and Assistant Chief of Wellness/Fitness to allow our Peer Fitness Trainers the ability to work with our employees related to the prevention of injuries, as well as the rehabilitation efforts of our injured employees. This should also include the involvement of Peer Fitness Trainers in the Safety Committee.

#4: A process for succession planning, individualized counseling and mentoring shall be developed to enhance the development of our personnel. This shall include:

- a). A system to track the ongoing educational goals, and education itself, of our personnel related to their professional development with an inherent goal of providing the employees assistance with their ongoing development.
- b). A system to track our employee's skills, a "skills inventory", which would provide the department with the ability to tap into these skills to further develop other department members.

#5: An improved process of targeting, recruiting and potentially hiring a more diverse workforce shall be developed and implemented. This could include a "Prospective Firefighter Orientation Day", coordination with the military's transition assistance team, as well as a South King Fire and Rescue "Recruitment Team".

Note: This was initiated in 2008.

#6: The current performance assessment/evaluation system should be revisited to ensure it is meeting the needs of the department and our personnel's growth.

Note: This has been completed for Operations personnel as of 2008, and now needs to be finalized for all Administrative and non-combat positions.

#7: Station #26 needs to be evaluated related to space considerations for physical fitness equipment tied into the "wellness/fitness" initiative in place within the department.

#8: The district's Board of Commissioners, Administration and Union shall continue to analyze long term medical benefit enhancements for LEOFF 2 employees.

Integrated Operations

The goals associated with integrated operations reflect South King Fire and Rescue's commitment to provide the highest level of emergency services to the community we serve. It also reflects our commitment that we will provide a safe working environment for all personnel.

Goal #1: We maximize quality training while maintaining high level emergency response capabilities.

Goal #6: We excel in providing consistent, safe, and professional emergency services for our community.

Vision: We will work cooperatively at providing well-trained, safe, and professional emergency services to our community and region.

Mission: Our mission is to gather and use the collective ideas from our department members and community to assist us in making decisions, modifications and improvements to our Emergency Operations and Training.

I. Strategic Objectives

- a. South King Fire and Rescue shall strive to meet or exceed NFPA 1710.
- b. South King Fire and Rescue shall provide a high level of emergency medical services from the time of call, to the point the patient(s) is at the hospital.
- c. South King Fire and Rescue shall train all personnel in the most efficient manner possible in order to meet State, County and Nationally established standards, with safety being of paramount emphasis.
- d. South King Fire and Rescue shall attain the status of being a fully accredited department.
- e. South King Fire and Rescue shall modify, upgrade or build facilities in order to ensure the highest level of service possible is provided internally and externally.

II. Successes which must be maintained

Ensuring all personnel are trained to provide a consistent fire attack within WISHA requirements for safety.

- a. Outfitting all front line engine companies with thermal imagers.
- b. Improving communications with all mutual aid agencies.
- c. Department officers shall be utilized to teach training programs which fall into their areas of expertise.
- d. Revise the JATC program to ensure that expectations are clearly established for the participating firefighter and his/her officer in each aspect of the program.
- e. South King Fire and Rescue shall continue to work towards expanding the relationship with the Federal Way Police Department and the Des Moines Police Department, with a goal of improving day-to-day emergency scene coordination.
- f. Consider a regional approach with other departments related to training, drilling, special operations, and responding.
- g. The budget process shall be utilized by the Administrative Team to determine which facilities upgrades/modifications shall be established as priorities on an annual basis.
- h. Revisiting all first due areas with regards to response times.
- i. Modify the front office/Prevention Division layout at the headquarters station (Station #62) to improve overall ergonomics and efficiencies.
- j. Integrating paramedic services into South King Fire and Rescue, either through a regional approach or individually within our department. (The initial ALS feasibility Study was completed in 2004; this issue will remain on the front burner through 2007).
- k. Modify the classroom, beanery and training areas to reflect the needs of current staffing at Station #68.

- l. Strongly consider not adding any new programs or projects for the near term future; evaluate the feasibility of eliminating some projects currently being handled by operations personnel.
- m. Establishing a BLS (Basic Life Support) transport policy, with or without a fee for transport.
- n. Having at least three (3) staffed aid cars, each staffed with 2 personnel, at least 75% of the time.
- o. The Deputy Chief of Training shall reinitiate the Training Advisory Group (TAG) with 6-8 members representing the different shifts and divisions of the department. Some goals of the new Training Advisory Group will be:
 - 1. To make recommendations related to ongoing training needs of the department.
 - 2. To develop a training “strategic plan” related to the merger of KCFPD #26, and the needs of personnel in both departments in a merged environment (pre and post merger).
- p. Strong consideration should be given to a RFP (request for proposal) related to ambulance transports from the private sector to improve ambulance response times in our service area.
- q. A team shall be assembled to research the need and viability of a 24-hour “Safety officer” (i.e. a 2nd Chief Officer toned out to all incidents or some other means of providing this level of safety and accountability).
- r. Reduce the impact of administrative paperwork and duties on the shift Battalion Chiefs by considering a Coordinating Captain, or Administrative Battalion Chief position, on day-shift, thus allowing them to spend more time with their assigned personnel to train, drill, conduct pre-fire plans, mentor, and improve the overall cohesiveness of the response crews.
- s. Establishing a team of employees to address the water/ice rescue problem, and make recommendations to the Administration and Labor.
- t. The Battalion Chiefs and Training Division will be tasked with determining the need for post incident analysis (PIA’s). The PIA’s shall be utilized to a greater extent in order to improve overall performance.

III. Probable Courses of Action

- a. South King Fire and Rescue shall work towards the following fire suppression goals:
 1. Having each engine company staffed with 4 personnel.
 2. Having a dedicated Ladder Truck (as opposed to cross-staffed), staffed with Rescue Team members.
 3. Having at least four (4) staffed aid cars, each staffed with 2 personnel, a minimum of 75% of the time.
 4. Meeting response goals as outlined within NFPA 1710.

This has been initiated and will be ongoing.

- b. South King Fire and Rescue shall work towards the following EMS goals:
 1. Establishing a team of employees to address the water/ice rescue problem, and make recommendations to the Administration and Labor.*
 2. Analyze the use and locations of aid cars as related to response times.*
 3. Meeting response goals as outlined within NFPA 1710.*

Some of these have been initiated (*), others have had nothing done to date.

- c. South King Fire and Rescue shall work towards the following training goals:
 1. The training schedule shall reflect the necessary items of importance for all personnel.*
 2. A reprioritization of JATC classes emphasizing the “train the trainer” concept with Company Officer’s conducting a majority of the RSI (required supplemental instruction) for apprentice firefighters.
 3. Training shall create additional training sites so as to reduce the impact on response times.*
 4. Training shall be the leader in utilizing technology to provide training to our personnel.
 5. Establish an acting officer training program, potentially linked into the Officer Development program.
 6. Post incident analysis (PIA’s) shall be utilized to a greater extent in order to improve overall performance.*
 7. An Officer Development program, tied into the JATC, shall be developed and implemented.
 8. The Training Center shall be evaluated for modification of the classrooms and drill grounds so

that manipulative training can reflect the makeup of our community and improve the training capabilities for all personnel. *

Some of these have been initiated (*), others have had nothing done to date.

- d. South King Fire and Rescue shall initialize a self-assessment using the accreditation program (CFAI), with the goal being to attain national accreditation for all divisions of the department.

This has been initiated with the completion goal established as 2010.

- e. South King Fire and Rescue should consider the following options for facilities modifications and upgrades:
 - 1. Review the property located at South 288th and I-5 related to whether this makes sense for a new station location in light of the merger with Des Moines (District #26).
 - 2. Expand the drill tower to allow for delivery of manipulative training sessions that prepare our personnel to successfully mitigate emergencies in warehouses, single family residences, garden style and center-hallway multi-family dwellings. *

Some of these have been initiated (*), others have had nothing done to date.

- f. South King Fire and Rescue shall consider a 4-platoon shift to reduce the impact of detailing personnel on a daily basis, and to improve our ability to provide necessary training.

A study of the 4-platoon shift has been incorporated into the current CBA.

- g. A system to improve the ability to access necessary training data, training records, and response time data shall be analyzed, with potential implementation via the budget process.

This has been initiated; to be followed up on continuously.

- h. The Training Division shall develop a system to ensure ongoing training on a “regular basis” related to high risk/low frequency types of responses.

This has been initiated; to be followed up continuously.

- i. An improved system of pre-fire planning shall be researched and implemented within the Operations Division of the department, coordinated with the Prevention and Training Divisions.
This has been initiated but requires follow through.

IV. Additional Issues/Future Considerations

- a. Consider placing the Rescue Team on the staffed ladder truck, perhaps utilizing a regional approach. Strong consideration should be given to placing the ladder truck and Rescue Team at Station #64, with the Hazardous Materials Team and apparatus located at Station #61 and the Marine Team located at Station #26.
This has been initiated; to be followed up on in 2009.
- b. Develop and conduct training for all officers and acting officers related to “in-service” response status for calls which involve assisting individuals who have fallen out of bed, or other related service-type requests.
Some work has been initiated on this objective on a case-by-case basis.
- c. Consider constructing new stations in the south end of the district (such as near 356th and Pacific Highway South), as well as in the north end of the district (the north hill area of the City of Des Moines), based on community needs and response time studies.
Response time studies are currently under way in 2007 and will continue in 2008 and beyond.

V. Action Steps

These are the next steps in the process of following through on the Strategic Goals and Action items. These shall be revisited and updated annually:

#1: The Deputy Chief of Support Services, the HR Manager, the Assistant Chief of Operations and the Fire Chief/Administrator shall initiate the self-assessment process for accreditation as a high priority.

#2: A team shall be developed to begin evaluating response data to determine compliance/non-compliance with the requirements of NFPA 1710. The team shall make recommendations to the Administration and Labor related to NFPA 1710 objectives not being met, if any.

- a). In addition, a cost analysis of meeting NFPA response standards, as well as meeting the objective of reaching a staffing level of 4 on all front line engine companies, shall be developed.**
- b). A full staffing analysis shall be conducted related to current and future placement of personnel and apparatus to meet the response goals as defined by the department.**

#3: The Operations Officers shall work towards ongoing collaboration and interaction with King County Medic One paramedics, with the goal of improved patient advocacy.

#4: An “aerial committee” shall be appointed to work on a recommendation for the department’s future needs after considering all options related to aerial operations.

- a) The final recommendation will be coordinated with all bond issue work in 2009/2010.**
- b) The committee shall consider aerials, quints, and other applicable apparatus to meet response needs.**

Leadership

The goals associated with leadership reflect South King Fire and Rescue's commitment to leading our employees competently, understanding and valuing diversity in the workforce and the community, and promoting personal mastery for all personnel.

Goal #7: We provide strong and competent leadership that values motivation, confidence and job satisfaction.

Goal #8: We are a leading force in community cultural knowledge and the positive integration of diversity within our organization.

Vision: We provide strong competent leadership at all levels within the organization, as well as within the community, and to institute processes that will foster good working relationships with the diverse population we serve.

Mission: Our mission is to develop leadership training programs that will improve knowledge, leadership skills, and abilities for all positions in the department, and to be a leading force in community cultural knowledge and the positive integration of diversity within our organization.

I. Strategic Objectives

- a. South King Fire and Rescue will have a promotional process in place that allows true leaders to attain leadership positions.
- b. South King Fire and Rescue will have an Officer Development program in place to help develop current and future officers into true leaders within the department.
- c. The leadership of South King Fire and Rescue shall lead by example, and shall enforce accountability in a fair and consistent manner.
- d. South King Fire and Rescue shall recruit personnel from diverse backgrounds.
- e. South King Fire and Rescue shall hire highly capable candidates.
- f. South King Fire and Rescue personnel will be knowledgeable of the diverse cultural makeup of the

community it serves, and will be responsive to the needs of this community.

II. Successes which must be maintained

- a. Re-establish Assistant Chiefs and Deputy Chiefs into the department hierarchy to allow for internal growth; to set a leadership standard for South King Fire and Rescue Chief Officers working within other County, State and Regional positions, many of whom are Deputy Chief ranks or higher; and to reestablish the paramilitary hierarchy which successfully existed for many years within the department before its elimination in the 1990's.
- b. South King Fire and Rescue shall continue to work towards expanding the relationship with the Federal Way and Des Moines Police Department's leadership team.
- c. Develop a philosophical policy that minimizes the reassignment of personnel to different stations whenever practically possible, with an emphasis on "crew stability and continuity". (The philosophy is sound; however, shift transfers still take place to balance out the needs of the organization).
- d. A process/system needs to be developed which will assist the Battalion Chiefs in spending more time mentoring their assigned Officers, relieving them of certain administrative duties and/or paperwork.
- e. The Administration and Labor shall augment the hiring process as necessary, with a goal of increasing diversity.
- f. An internal education program shall be developed which will provide a minimum of 16 hours of training annually to all departmental officers, as outlined in the current CBA. This education shall include training and education related to leadership, administration, departmental finances and budgeting, legislative processes, program management, strategy and tactics, and a host of other topics taught by South King Fire and Rescue Officers and Chiefs.

III. Probable Courses of Action

- a. Consider restructuring the current promotional process to eliminate the "one-day" exclusively external testing process, with more emphasis on promoting true "leaders"

utilizing both internal and external administration of the process.

This has been revisited and will be part of ongoing contract negotiations.

- b. Develop a communications model that will be implemented throughout the department which will ensure that all members are informed and aware of all aspects of this organization. This should include more use of the Tandberg system related to morning “tie-ins” with the Administrative Team.
This has been initiated and will be ongoing.
- c. The department should consider having language skills classes, representatives from other ethnic backgrounds to educate our personnel related to religious tenants, and classes on cultural differences that make up our community in an effort to improve our delivery system to all the citizens we serve.
Nothing done to date.
- d. Create an avenue (program) that allows department members to share the information they have learned at outside classes/training sessions, seminars or conferences with the rest of the department. This will also include the development of an instructor’s list for use internally.
This objective has been initiated, with additional follow through required.
- e. A succession plan shall be developed to assist in the future transition of department personnel into the ranks of middle management (Lieutenants and Captains) and a number of upper management positions (certain Chief Officer positions). However, flexibility must be maintained to allow the potential for hiring civilian or external candidates who possess certain KSA’s necessary for the growth of the department (i.e. a CPA to eventually coordinate the Finance Division is a potential option for consideration).
This has been initiated and will be ongoing.
- f. A mentoring process, linked in with the ongoing evaluation process and JATC program, shall be developed and implemented for probationary officers.
This has been initiated and shall continue.

IV. Action Steps

These are the next steps in the process of following through on the Strategic Goals and Action items. These shall be revisited and updated annually:

#1: The Administration and Labor shall augment the hiring process as necessary, with a goal of increasing diversity. Support shall be given to the JATC program as well as to the potential “Recruitment Team” developed within South King Fire and Rescue.

#2: The Administration and Labor shall appoint members to work on a team with their assigned goal being the establishment of an Officer Development program that links into the department’s promotional process. This process shall have an additional goal of assisting in the future transition of department personnel into the ranks of middle management (Lieutenants and Captains) and upper management (all Chief Officer Positions).

#3: An “Operations Career Development” program shall be developed and implemented that addresses pre-officer training, pre and post-promotion readiness and mentoring, and ongoing education for all leadership positions. This program should be linked into the Officer Development program.

- **The plan would outline an individual’s career path and career objectives.**

#4: The Administration and Labor shall finalize and implement a communications model to improve the sharing of information within the department (i.e. numbered memos, written policies, newsletters, and all forms of communication shall be revisited). An improved and enhanced form of communication, using Tandberg and the addition of Sharepoint with the possibility of being able to use Tandberg to be in contact other departments to share training and other information.

Community

The goals associated with community reflect South King Fire and Rescue's commitment to the entire communities of Federal Way and Des Moines related to fire and life safety, the prevention of fire and injuries, and the education of all the citizens we serve regarding the services available to them provided by the department.

Goal #4: We have communities that are educated, aware and supportive of our services.

Goal #9: We provide awareness and prevention education to the community to reduce risks to life and property.

Vision: Our community has low risk of fires and injury, is well educated on prevention, prepared to handle emergencies, aware and supportive of our services.

Mission: Our mission is to provide effective prevention and public education programs that reduce the risk to life and property, and to maintain awareness and increase the community's knowledge of the department and our services.

I. Strategic Objectives

- a. South King Fire and Rescue will work towards prevention of fire and severe injuries within the community we serve.
- b. South King Fire and Rescue will educate our community on the services that are provided by the department.
- c. South King Fire and Rescue will work towards reducing the number of non-emergency alarms.
- d. South King Fire and Rescue shall use modern technology to deliver its messages to the public.
- e. South King Fire and Rescue shall make prevention and public education a department priority.

II. Successes from which must be maintained

- a. Placing Public Access Defibrillation (PAD) devices in all schools and major public buildings in Federal Way.
- b. Increasing the use of technology to provide training and education to businesses and schools. The programs

could be developed in partnership with area businesses (i.e. Weyerhaeuser and Christian Faith Center) as well as other public entities (the City of Federal Way and City of Des Moines).

- c. Utilizing engine companies for public relations events.
- d. Using the City television networks to assist in educating the public.
- e. Increasing involvement with the community via fire extinguisher classes, first aid classes, etc.
- f. Continuing, and potentially enhancing, our visibility and education efforts in the schools (including having all engine companies involved with the Kindergarten classes).
- g. Developing a cadre of trained volunteers to support public education and citizen training efforts.
- h. The Prevention and Public Education Divisions shall educate our operations personnel to be better able to perform inspections, work within the scope of new education programs, as well as to assist more efficiently at emergency scenes during investigations.
- i. Having our Honor Guard perform at community events.
- j. Providing a “State of the Fire Department” presentation on an annual basis to City Officials, Service Clubs, and also on the City television network.
- k. South King Fire and Rescue shall consider a regional approach to providing services, both operationally as well as within the realm of prevention and education.
- l. A team of firefighters, officers, Chief Officers and Public Education Specialists shall be established to prioritize the department’s involvement in community events, and to determine which venues firefighters should be involved in.
- m. The Prevention Division and Training Division shall work together to develop a training program designed to enhance the knowledge level of all personnel related to the fire codes, things to look for to help the fire investigators, etc.

- n. The Administration and Labor shall develop strategies to inform the public about the adopted South King Fire and Rescue Strategic Leadership Plan.
- o. Initiating a program to educate the public on the proper use of 9-1-1. (**NOTE:** This will be an ongoing process).
- p. Educating medical clinics about 9-1-1, with an explanation regarding the various response modes and transportation options. (**NOTE:** This will be an ongoing process, with a renewed effort in **2008/2009**).
- q. Educating nursing homes and home health care facilities regarding the fire departments services, including information on end-of-life decisions. (**NOTE:** This will be an ongoing process.)
- r. Focusing in on our prime cause of fires to educate the public (kitchen fires as of this time).
- s. Utilizing our web page to better educate the public.
- t. The Public Education Specialists shall continue to work with the department's Information Systems Division and the City of Federal Way to explore ways to further educate the public regarding fire prevention, and the department as a whole (i.e. via the web site, utilizing the Federal Way and Des Moines public TV channel, etc.).
- u. South King Fire and Rescue shall formalize a format for initiating a Public Information Officer (PIO), or other form of media liaison, to allow for a rapid response to emergency incidents when required.
- v. Initiating a water safety program to be taught to the community in the springtime, before the summer swimming season begins.
- w. Targeting automatic fire alarms to work towards the prevention of false alarms.
- x. Having regular "get out and meet the public" days, wherein engine companies go out to businesses to pass out pamphlets, answer questions, and meet with the public.

- y. A program shall be developed to coordinate the annual reporting requirements of HB 1756, which has been codified within RCW 52.33.
- z. Adding one deputy fire marshal to assist with the workload in prevention, and to provide training for operations division personnel.
- aa. Exploring opportunities to support the Citizen Corps, related to Homeland Security, as it may develop in the communities we serve.
- bb. South King Fire and Rescue shall take a leadership role related to Emergency Management and Disaster Preparation within the communities we serve. This leadership role shall include, among other things:
 - 1. Updating disaster plans.
 - 2. Developing a pandemic flu plan.
 - 3. Analyzing station needs related to food, water, and fuel for an extended period of time during a disaster (i.e. 9 days worth of supplies and fuel with adequate generator power).
- cc. Utilizing various sources (i.e. different business mailings and company brochures, etc.) to get our safety message out, and to continue our emphasis on fireworks regulations.
- dd. Continue the program of ongoing communications and direct contact with our neighboring police agencies with a goal of improved relationships and enhanced scene coordination. This will include Federal Way PD, Des Moines PD, Auburn PD, WSP, and the King County Sheriff.

III. Probable Courses of Action

- a. South King Fire and Rescue shall **consider and evaluate** implementation of the following programs to support its prevention efforts:
 - 1. Continue the program of contacting the public after an emergency incident to elicit feedback from the community we serve (i.e. a postcard program or direct contact).
This has been initiated with “After the Fire” meetings, meetings with citizen groups, and the efforts to assist our citizens after a major

incident via the Firefighter's Foundation (a non-profit group of internal employees).

2. Adding one or more "full time commissioned" investigators, or an investigation program.
This has been initiated (all investigators now are certified); in addition, two (2) positions are non-rotatable as of 2009 to assist with continuity in the division and with investigation skills.
3. Working with the local hospitals (St. Francis, Highline, Valley Medical Center, Auburn Regional, the COAD and the VOAD), Federal Way Police Department, Des Moines Police Department, Auburn Police Department, private ambulance providers, religious organizations and the health department regarding a plan for dealing with the homeless disenfranchised patients.
This has been initiated and will be ongoing.
4. Increase the number of public education opportunities and public interactions involving South King Fire & Rescue personnel and the communities we serve (i.e. "After the Fire" meetings, etc.).
This has been initiated and will be ongoing.

IV. Additional Issues/Future Considerations

- a. A short-term assignment should be explored for new officers to spend time in the Prevention Division to add to their education. This should be analyzed and potentially folded into the proposed Officer Development program.
Nothing done to date.
- b. Consideration should be given to having Operations personnel verifying hydrant locations and tagging hydrants in new developments as part of a pre-fire planning process.
Nothing done to date.
- c. Consideration should be given towards implementing local market research related to our communities' local level of support, willingness to pay for additional services (i.e. BLS transports), and future trends in emergency services.
Nothing done to date.

- d. An evaluation of alternate response methods should be evaluated when demand for emergency services increases to the point where non-emergency responses (i.e. service responses) may need to be handled by other than front line firefighters.

This has been initiated; more work required in 2007.

V. **Action Steps**

These are the next steps in the process of following through on the Strategic Goals and Action items. These shall be revisited and updated annually:

#1: The Administration, Labor, the Firefighter's Foundation, and the Public Education Officers shall meet to coordinate annual activities designed to educate and inform the public about the fire department, our goals and overall mission.

Note: This has been initiated and will be ongoing.

#2: The Public Education Division shall work with the Korean, Ukrainian and Spanish speaking community leadership groups to identify improved methods related to getting our public education messages out to our diverse community.

Note: Significant progress has been made on this action step.

#4: A program to fund placing Public Access Defibrillation (PAD) devices in all schools and major public buildings within the City of Des Moines shall be researched and implemented.

Note: This has been initiated and will be ongoing.

#5: Educate the public on the costs and benefits of the upcoming bond issue (2010 or beyond) with meetings, presentations, handouts and information on the website by no later than February of 2010 (or as linked into the final date determined for the bond issue to be on the ballot).

#6: The fire district shall work towards the adoption of a residential sprinkler ordinance in the City of Federal Way and the City of Des Moines. The goal will be to coordinate efforts in 2009 and 2010 with the Washington Fire Chiefs, the Washington Fire Commissioners Association, the Washington State Council of Fire

Fighters, the NFPA and the Sprinkler Coalition in this united effort.

#7: The fire district shall enhance our current public outreach efforts with an emphasis on utilizing local statistics, local partnerships, and our vast array of resources to design programs with a goal of reducing fires and injuries in our service area, and thus improving the overall quality of life for our citizens. An emphasis in 2009/2010 shall be on providing smoke detectors and smoke detector batteries to our citizens.

Financial

The goal associated with finance reflects South King Fire and Rescue's commitment to adequately fund the services provided to the community we serve, and to be fiscally responsible with the funds the department receives.

Goal #5: We have stable funding that allows for growth and supports our mission.

Vision: We have sufficient funds to provide our community with cost effective and efficient emergency services.

Mission: Our goal is to influence, gather and use the collected ideas from elected officials, community, and fire department members to assist us in providing sound fiscal management and stable funding resources.

I. Strategic Objectives

- a. South King Fire and Rescue will be a well funded and financially stable department, with a high level of fiscal responsibility evident throughout the organization.
- b. South King Fire and Rescue shall consider alternative funding sources as future revenues become harder to access.
- c. All members of South King Fire and Rescue shall be well educated on departmental funding and the fiscal responsibilities each member is accountable for within the organization.

II. Successes which must be maintained

- a. South King Fire and Rescue shall consider the following funding options to meet its needs in the future: regular taxing levies (property), lid lifts, private donations, and grants.
- b. South King Fire and Rescue shall work towards regionalization of services, such as hazardous materials team responses, rescue team responses, and water/ice rescue responses to reduce the direct cost impact on the department, while at the same time improving efficiencies

in the level of initial emergency response.

- c. A team of interested members shall be developed to assist the HR Manager and Administrative Assistant with the development of grant requests for capital items and/or new programs (i.e. thermal imagers, a surface water rescue team, etc.).
- d. South King Fire and Rescue shall consider the following funding options to meet its needs in the future: Lid Lifts in 2003, 2004, 2005, 2006 and 2007.
- e. Work with the legislature to ensure that funding is maintained or improved for junior taxing districts.
- f. South King Fire and Rescue shall explore the possibility of merging with other fire districts to help improve the financial stability of all interested departments in the area.
- g. All members of the department shall receive training on the funding mechanisms available to a fire district. (This shall be annual training provided to interested personnel).
- h. All members of the department shall receive training on the financial controls in place within the department, and the role they play within the fiscal responsibility expected of all personnel. (This shall be annual training provided to interested personnel).
- i. Explore options to eliminate the Hospital District (Valley Medical District #1) from the fire district boundary. (Note: while not eliminated, the fear of pro-rationing has been reduced due to legislation passed in 2005 to protect fire districts by an additional 25 cents of levy capacity).
- j. The Administration and Commissioners of South King Fire and Rescue shall be involved in the process related to the development of a plan for the 2007 EMS Levy. Emphasis shall be placed on ensuring that ALS and BLS issues are identified, funded and coordinated to meet the needs of the Federal Way and Des Moines communities.
- k. Work with the legislature to ensure that funding is maintained or improved for junior taxing districts (e.g. passage of a bill to allow Lid Lifts to last for 6 years at a time, or multi-year Lid Lifts lasting longer than 1 year).

- l. The service benefit charge should be considered for future funding, as it provides for 6 years worth of revenues after one ballot measure passes.
- m. The Board of Fire Commissioners, the Administration and Labor shall meet to discuss potential funding options for South King Fire and Rescue's future, with the goal of consensus on our fiscal direction.
- n. The Finance Division shall hire (as needed) and cross-train all assigned personnel to ensure a continuity of business related to payroll, accounts receivable and payable, as well as applicable HR needs.

III. Probable Courses of Action

- a. South King Fire and Rescue shall consider the following funding options to meet its needs in the future:
 - 1. Regular property tax levies
 - 2. Lid Lifts (1 year, 6 year, multi-year or temporary).
(NOTE: The next Lid Lift would become necessary in the fall of 2013, for implementation in 2014).
 - 3. Bond issues **(NOTE: This is currently planned for 2010).**
 - 4. Excess levies
 - 5. Service Benefit Charges
 - 6. Private donations
 - 7. Grants
 - 8. SEPA Review Fees
 - 9. Patient Transport Fees
 - 10. Other options

This has been initiated and will be ongoing.
- b. The department should consider charging for BLS transports.
This has been initiated and will be ongoing.
- c. The capital reserve/replacement fund shall be analyzed to determine that which is actually required for the long term needs of the department.
This has been initiated and will be ongoing.
- d. South King Fire and Rescue shall explore the possibility of merging with other fire districts, or utilizing the Fire Authority System to consolidate/merge municipal fire departments and fire districts in the area, to help

improve the financial stability of all interested departments in the area.

This has been initiated and will be ongoing.

- e. Explore options of receiving additional revenues through the City of Federal Way and/or the City of Des Moines (i.e. implementation of legislation to allow for the collection of local impact fees for new developments).

Legislative work initiated; more to follow in 2008/09.

- f. Explore options to eliminate the Hospital District (Valley Medical District #1) from the fire district boundary.

This has been initiated.

IV. Additional Issues/Future Considerations

- a. The service benefit charge should be considered for future funding, as it provides for 6 years worth of revenues after one ballot measure passes.

This has been researched fully in 2007, with the current status to not proceed with the benefit charge. This will remain an option for the long term future.

IV. Action Steps

These are the initial steps to begin the process of following through on the Strategic Goals and Action items. These shall be revisited and updated annually:

#1: The Board of Fire Commissioners and Administration shall establish a list of funding options for capital purchases which includes various revenue sources appropriate to the size of the project. Examples could include different sources of revenue and financing packages depending upon the specific project (i.e. voter approved bonds, GO Bonds, Excess Levy, Grants, etc.).

#2: The Board of Commissioners and Administration shall monitor on an ongoing basis the capital reserve fund to determine that the fund balances and listed equipment are reasonable and prudent.

#3: The Finance Division and Administrative Team shall analyze the accounting system in use by the fire district to determine if it meets our short and long term needs, or if an alternate system better serves our overall objectives. This analysis shall be completed by mid-2009.

#4: The fire district's Board of Fire Commissioners, Administrative Team, and Strategic Leadership Planning Team shall plan for and develop the financial plan for a potential March of 2010 bond issue by no later than August of 2009.

This shall include the following key dates:

- **February-August of 2009: Complete all bond issue work related to costs, projects to be funded, etc.**
- **September/October of 2009: Presentation to full Board of Fire Commissioners for augmentation as required.**
- **November/December of 2009: Final approval by the Board of Fire Commissioners and filing by resolution with King County Elections.**
- **January/February/March of 2010: The informational campaign related to the bond issue.**
- **March of 2010: The ballot issue itself requiring a 60% yes vote with a 40% validation from the prior General Election in order to validate and pass.**

FEDERAL WAY FIRE DEPARTMENT

MASTER STRATEGIC
LEADERSHIP TEAM
WORK PRODUCT
2003

This section will be updated on an annual basis to contain a list of the goals and operational action items which have been completed, or that have been eliminated from any further consideration.

Human Resource Goals Completed

- a. Finalize and adopt the Strategic Leadership Plan.
 - Adopted by the Board in November 21st, 2002.
- b. The daily schedule for all personnel shall be streamlined to allow for the necessary work to be completed, without undue stress or burnout of personnel.
 - Completed by Administrative Team and Officers.
- c. The Strategic Leadership Plan shall be reviewed on an ongoing basis, with annual updates intended to meet changing community and departmental needs.
 - Quarterly reviews and annual updates initiated.
- d. The Strategic Leadership Plan shall have a reporting mechanism developed to report back on measurable outcomes associated with the established goals and action items.
 - Quarterly reviews by the planning team ensure outcomes are completed.
- e. The Deputy Chief shall head up a team that will formalize the daily schedule to incorporate all daily tasks.
 - Completed and initiated by the Deputy Chief and department officers.

Integrated Operations Goals Completed

- a. Ensuring all personnel are trained to provide a consistent fire attack within WISHA requirements for safety.
 - Policies and training reinforce the standard.
- b. Outfitting all front line engine companies with thermal imagers.
 - Purchased and outfitted during 2003 via Fire Act Grant.
- c. Improving communications with all mutual aid agencies.
 - Radio templates all upgraded via Valley Com to ensure compatibility.
- d. Department officers shall be utilized to teach training programs which fall into their areas of expertise.
 - The “train the trainer” concept utilized for a number of educational opportunities.

- e. Revise the JATC program to ensure that expectations are clearly established for the participating firefighter and his/her officer in each aspect of the program.
 - The JATC manual and objectives have been updated for consistency, with expected outcomes listed.
- f. The Federal Way Fire Department shall continue to work towards expanding the relationship with the Federal Way Police Department, with a goal of improving day-to-day emergency scene coordination.
 - Ongoing meetings, breakfasts hosted by the fire department, and the move by Prevention to City Hall has improved the relationship.
- g. Consider a regional approach with other departments related to training, drilling, special operations, and responding.
 - Zone 3 training has been initiated on a trimester basis for all departments.
- h. The budget process shall be utilized by the Administrative Team to determine which facilities upgrades/modifications shall be established as priorities on an annual basis.
 - The budget process and capital reserves have been utilized to ensure our facilities are maintained.

Leadership Goals Completed

- a. Re-establish Assistant Chiefs into the department hierarchy to allow for internal growth; to set a leadership standard for Federal Way Chief officers working within other County, State and Regional positions, many of whom are Assistant Chief ranks or higher; and to reestablish the paramilitary hierarchy which successfully existed for many years within the department before its elimination in the 1990's.
 - Assistant Chiefs were reintroduced to the department's hierarchy during 2003.
- b. Create an avenue (program) that allows department members to share the information they have learned at outside classes/training sessions, seminars or conferences with the rest of the department.

- The “train the trainer” concept and Training Division follow up continues to refine this objective.
- c. The Federal Way Fire Department shall continue to work towards expanding the relationship with the Federal Way Police Department’s leadership team.
 - This is an ongoing process with many successes as noted previously.
- d. The Fire Chief shall initiate an Administrative Assistant position, with one of the duties of the position being to take a great deal of the scheduling and planning burden off the Operations Battalion Chiefs, thus allowing them to work more closely with their assigned officers.
 - The Administrative Assistant position (initially Gene Beasley and later Lauri Perry) was initiated in 2003.

Community Goals Completed

- a. Placing Public Access Defibrillation (PAD) devices in all schools and major public buildings.
 - The “Project Jean” team has worked to place PAD’s in schools and in buildings throughout Federal Way. The work on this issue shall continue.
- b. Increasing the use of technology to provide training and education to businesses and schools. The programs could be developed in partnership with area businesses (i.e. Weyerhaeuser and Capital One) as well as other public entities (the City of Federal Way).
 - This is an ongoing process as coordinated via the Public Education team.
- c. Utilizing engine companies for public relations events.
 - On duty companies are utilized for many public relations/public education activities.
- d. Using the City television network to assist in educating the public.
 - This is an ongoing project, with success gleaned from the kitchen fire program over the airwaves.
- e. Increasing involvement with the community via fire extinguisher classes, first aid classes, etc.

- This is an ongoing project for Public Education and our on duty personnel.
- f. Continuing, and potentially enhancing, our visibility and education efforts in the schools (including having all engine companies involved with the Kindergarten classes).
- This is an ongoing project for Public Education and our on duty personnel.
- g. Developing a cadre of trained volunteers to support public education and citizen training efforts.
- We have recruited several volunteers to assist with public education efforts.
- h. The Prevention and Public Education Divisions shall educate our operations personnel to be better able to perform inspections, work within the scope of new education programs, as well as to assist more efficiently at emergency scenes during investigations.
- Public Education has provided classes for all Operations personnel.
- i. Having our Honor Guard perform at community events.
- This is ongoing with many successful venues having been attended.
- j. Providing a “State of the Fire Department” presentation on an annual basis to City Officials, Service Clubs, and also on the City television network.
- This has been initiated by Chief Church and Public Education as an annual event.
- k. The Federal Way Fire Department shall consider a regional approach to providing services, both operationally as well as within the realm of prevention and education.
- This has been initiated in Zone 3 with Training, Public Education, Emergency Management and Hazardous Materials responses leading the way.
- l. A team of firefighters, officers, Chief Officers and Public Education Specialists shall be established to prioritize the department’s involvement in community events, and to determine which venues firefighters should be involved in.

- Members of the Administrative Team, Operations and Public Education met and determined priorities.
- m. The Prevention Division and Training Division shall work together to develop a training program designed to enhance the knowledge level of all personnel related to the fire codes, things to look for to help the fire investigators, etc.
- The Prevention Division now provides classes on at least an annual basis for all Operations personnel.
- n. The Administration and Labor shall develop strategies to inform the public about the adopted Federal Way Fire Department Strategic Leadership Plan.
- The Strategic Plan has been communicated via news articles, our web site, and is brought up openly in community venues as something we are proud of.

Financial Goals Completed

- a. The Federal Way Fire Department shall consider the following funding options to meet its needs in the future: lid lifts, private donations, and grants.
- The department has successfully passed Lid Lifts in 2001, 2002 and 2003. The department has also received well over \$750,000 in Federal grant funding due to our department's efforts.
- b. The Federal Way Fire Department shall work towards regionalization of services, such as hazardous materials team responses, rescue team responses, and water/ice rescue responses to reduce the direct cost impact on the department, while at the same time improving efficiencies in the level of initial emergency response.
- A regional hazardous materials response within Zone 3 has been initiated. Rescue coordinates regionally through the Urban Search and Rescue Team.
- c. A team of interested members shall be developed to assist the Personnel Coordinator and Administrative Assistant with the development of grant requests for capital items and/or new programs (i.e. thermal imagers, a surface water rescue team, etc.).

- The department has successfully developed and been awarded grants in the amount of \$750,000.

FEDERAL WAY FIRE DEPARTMENT

MASTER STRATEGIC
LEADERSHIP TEAM
WORK PRODUCT
2004

This section will be updated on an annual basis to contain a list of the goals and operational action items which have been completed, or that have been eliminated from any further consideration.

Human Resource Goals Completed

- a. Management shall set the example by prioritizing time for physical exercise or health and wellness education.
 - The Deputy Chief and Officers have established fitness as a priority, with many crews working out first thing in the morning.
- b. Education shall be prioritized and provided to each member of this department to assist them in establishing a fitness, health and wellness regimen.
 - Thanks to funding from a grant, our department members have been provided with new equipment and education on wellness and fitness.
- c. The department will strive to meet or exceed the provisions contained within the “IAFF/IAFC Wellness Fitness Initiative” for all employees.
 - The department now meets the provisions of the IAFF/IAFC Wellness Fitness Initiative, including annual physicals and fitness tests for all personnel. Coupled with our EAP and Chaplaincy programs, wellness/fitness is a huge priority for our personnel.
- d. An improved system of personnel evaluations/assessments will be developed and implemented (or eliminated altogether).
 - A web-based evaluation system has been developed with implementation planned for January of 2005.
- e. All work stations should be monitored and updated as needed to ensure compliance with ergonomic requirements.
 - Work stations for all front office, accounting and Prevention personnel have been updated to meet ergonomic requirements.
- f. Physical fitness equipment and programming should continually be upgraded and available to meet the needs of all department employees.
 - Major upgrades took place in 2004, with annual updates budgeted as needed.

Integrated Operations Goals Completed

- a. Revisiting all first due areas with regards to response times.
 - The Deputy Chief and Battalion Chiefs have modified all response zones to ensure improved response times.
- b. Modify the front office/Prevention Division layout at the headquarters station (Station #62) to improve overall ergonomics and efficiencies.
 - Prevention moved to City Hall and the front office was totally remodeled with all HR and accounting functions moving into the downstairs area in the fall of 2004.
- c. Integrating paramedic services into the Federal Way Fire Department, either through a regional approach or individually within our department.
 - The initial ALS feasibility Study was completed in 2004; this issue will remain on the front burner through 2007.
- d. Modify the classroom, beanery and training areas to reflect the needs of current staffing at Station #68.
 - This project was completed in early 2004.
- e. Strongly consider not adding any new programs or projects for the near term future; evaluate the feasibility of eliminating some projects currently being handled by operations personnel.
 - The Administration and leadership of the department works diligently to maintain a balance between programs and community needs.

Leadership Goals Completed

- a. Develop a philosophical policy that minimizes the reassignment of personnel to different stations whenever practically possible, with an emphasis on “crew stability and continuity”.
 - The philosophy is sound; however, shift transfers still take place to balance out the needs of the organization.

Community Goals Completed

- a. Placing Public Access Defibrillation (PAD) devices in all schools and major public buildings.
 - This will be an ongoing process, with many successes to date.
 - The Federal Way Firefighters Foundation has taken a huge lead in coordinating the placement of PAD devices by leading the Project Jean process.
- b. Initiating a program to educate the public on the proper use of 9-1-1.
 - This has been initiated and will be an ongoing process.
- c. Educating medical clinics about 9-1-1, with an explanation regarding the various response modes and transportation options.
 - This was initiated in 2004 to include the Fire Marshal, A/C of EMS and Public Education together with Operations personnel. This will be an ongoing process.
- d. Educating nursing homes and home health care facilities regarding the fire departments services, including information on end-of-life decisions.
 - This was initiated in 2004 to include the Fire Marshal, A/C of EMS and Public Education together with Operations personnel. This will be an ongoing process.
- e. Focusing in on our prime cause of fires to educate the public (kitchen fires as of this time).
 - This continues to be a focus area annually by Prevention and Public Education personnel.
- f. Utilizing our web page to better educate the public.
 - This continues to be a focus area annually by Prevention and Public Education personnel.

Financial Goals Completed

- a. The Federal Way Fire Department shall consider the following funding options to meet its needs in the future: Lid Lifts in 2003 and 2004.
 - The department has successfully passed Lid Lifts in 2001, 2002, 2003 and 2004.
- b. Work with the legislature to ensure that funding is maintained or improved for junior taxing districts.
 - The department is taking the lead in developing legislation to address the 101% lid issue created by Initiative 747, as well as addressing the district overlap issue with potential funding pro-rationing.
- c. The Federal Way Fire Department shall explore the possibility of merging with other fire districts to help improve the financial stability of all interested departments in the area.
 - Efforts related to a potential merger with District #26/Des Moines have consumed a great deal of time during 2004, with the Board of Commissioners in Des Moines voting in the fall of 2004 to formally pursue a merger with Federal Way!!!
- d. All members of the department shall receive training on the funding mechanisms available to a fire district.
 - Chief Church initiated this during officer development evening classes. This shall continue to be annual training provided to interested personnel.
- e. All members of the department shall receive training on the financial controls in place within the department, and the role they play within the fiscal responsibility expected of all personnel.
 - Chief Church initiated this during officer development evening classes. This shall be annual training provided to interested personnel.

FEDERAL WAY FIRE DEPARTMENT

MASTER STRATEGIC
LEADERSHIP TEAM
WORK PRODUCT
2005

This section will be updated on an annual basis to contain a list of the goals and operational action items which have been completed, or that have been eliminated from any further consideration.

Human Resource Goals Completed

- a. A process shall be developed to assist in the proposed integration of KCFPD #26 personnel into the Federal Way Fire Department in a merged environment, including their involvement in the Strategic Leadership Planning processes.
 - A comprehensive process was developed and implemented to support the merger of all personnel.

Integrated Operations Goals Completed

- a. Establishing a BLS (Basic Life Support) transport policy, with or without a fee for transport.
 - A policy was developed and implemented which supported fire department transports without a fee, while still utilizing ambulance transports as the primary source of transports.
- b. Having at least 3 staffed aid cars, each staffed with 2 personnel. **NOTE: This objective has now been modified in a merged environment, with the new objective being to achieve 4 staffed aid cars.**
 - Aid 62, 64 and 26 are all staffed on a regular basis, while Aid 63 is occasionally staffed when staffing levels permit.
- c. The Deputy Chief of Training shall reinitiate the Training Advisory Group (TAG) with 6-8 members representing the different shifts and divisions of the department. Some goals of the new Training Advisory Group will be:
 - To make recommendations related to ongoing training needs of the department.
 - To develop a training “strategic plan” related to the merger of KCFPD #26, and the needs of personnel in both departments in a merged environment (pre and post merger).
 - The TAG has been reinitiated and reinvigorated, and in providing direction on the training needs of the department.

Community Goals Completed

- a. Federal Way Fire Department shall formalize a format for initiating a Public Information Officer (PIO), or other form of media liaison, to allow for a rapid response to emergency incidents when required.
 - A PIO response plan has been developed and implemented to ensure coverage 24 hours a day.
- b. Initiating a water safety program to be taught to the community in the springtime, before the summer swimming season begins.
 - The Public Education Division coordinates with area classes to ensure water safety programs are available to our citizens.
- c. Targeting automatic fire alarms to work towards the prevention of false alarms.
 - The Prevention Division targeted false alarms and the businesses where false alarms are occurring on a routine basis, with success in reducing the number of alarms through our prevention efforts.
- d. Having regular “get out and meet the public” days, wherein engine companies go out to businesses to pass out pamphlets, answer questions, and meet with the public.
 - The Operational crews are routinely involved in Public Education programs out in the public.

Financial Goals Completed

- a. Explore options to eliminate the Hospital District (Valley Medical District #1) from the fire district boundary. (Note: while not eliminated, the fear of pro-rationing has been reduced due to legislation passed in 2005 to protect fire districts by an additional 25 cents of levy capacity).
 - Options have been identified for the aforementioned withdrawal process. However, legislation recently adopted now provides extra protection for fire districts in the form of an extra 25 cents of pro-rationing protection above the Constitutional \$5.90/\$1000 when a hospital district would otherwise have reduced the fire district levy.

- b. The Federal Way Fire Department shall explore the possibility of merging with other fire districts to help improve the financial stability of all interested departments in the area.
 - In 2006, the Federal Way Fire Department and KCFPD #26 merged to form South King Fire and Rescue. Talks with other neighboring departments related to mergers continues.
- c. The Administration and Commissioners of Federal Way Fire Department shall be involved in the process related to the development of a plan for the 2007 EMS Levy. Emphasis shall be placed on ensuring that ALS and BLS issues are identified, funded and coordinated to meet the needs of the Federal Way and Des Moines communities.
 - Fire Chief/Administrator Church, Commissioner Rickert, Deputy Chief Plumlee and Commissioner Hershey have all been involved in the EMS Levy process development and support.

Note:

The following objective was an over arching and long term goal for the fire department, and was successfully completed in 2005/2006. It is noted here separately as it was the major focus of the department during 2005.

Coordinate a potential merger with District #26/Des Moines.

**Lead: Chief Al Church
Commissioner John Rickert
Commissioner Roger Hershey
Local #2024 Executive Board**

Timeline: Develop the full merger plan, implement the SEPA review process, implement the BRB process, and be prepared for a potential merger election in Des Moines in September of 2005.

Status: A great deal of work has already been completed during 2002, 2003 and especially 2004 on this effort. It could potentially come to a successful culmination during 2005.

NOTE: SUCCESS was achieved in September of 2005, with an 83% yes vote to allow the merger of District #26 with Federal Way Fire to form: *SOUTH KING FIRE AND RESCUE* effective January 1st, 2006.

SOUTH KING FIRE & RESCUE

MASTER STRATEGIC
LEADERSHIP TEAM
WORK PRODUCT
2006

This section will be updated on an annual basis to contain a list of the goals and operational action items which have been completed, or that have been eliminated from any further consideration.

2006 Planning Process

As part of the 2006 process for updating the Strategic Plan on an ongoing basis, the S.W.O.T. Analysis was utilized to analyze the newly merged South King Fire and Rescue. The results of the SWOT analysis, which occurred on April 12th and is shown below, was utilized as the framework to update, augment, eliminate and add new objectives to support the strategic goals of the department.

Strengths

- Progressive/Forward
- Well motivated work force
- Talented & dedicated workforce
- Funding
- Labor/Management
- Visible
- Size and economy of scale
- We know “How to Merge”
- Can provide emergency management to others
- Have well trained truck company “force”
- Well connected regionally and at state level
- Medical Evals & WFI
- TAG Committee with engaged members
- Not afraid to do self examination and change
- Support for higher education
- Relationship with Cities

Weaknesses

- Fire RMS/Sun Pro = inability to get training reports
- Funding (limited)
- Diversity
- Not enough time on high risk, low frequency incidents
- More structured approach to pre-fire planning
- Need for more personnel in training and prevention
- Need for added Administration Support
- Dedicated Ladder Truck
- Jack of all trades / Master of none
- Running out of space at older stations
- Technology
- Under utilized personnel

- Evaluation process
- B/C's workload
- Lack of 24 hr Safety Officer
- Aging work force
- Relationship with King County (DDES)
- Lack of succession plan in Prevention
- Lack of succession planning

Opportunities

- Funding
- More visibility
- More structured approach to pre fire planning
- Merger opportunities
- Can provide Emergency Management to others
- Slow Down aging process and reduce injuries via safety committee
- Look at EMS Transport Policy and private providers
- Career education model to be identified
- Better utilize our personnel
- Opportunity to mentor future leaders
- 2nd Battalion Chief
- Expand Training Facility
- Accreditation
- Meet or exceed 1710
- Can emerge as regional leader in Training and Special Ops
- Increase demand for non-emergency service

Threats

- Funding
- Additional/new government entities to effect our taxation
- Response/time issues
- Experienced members ready to retire
- Lack of succession planning
- Increased demand for non emergency services
- On going threats (i.e. pandemic flu)

2006 Successes

The year 2006 marked the first year in a merged environment with the Federal Way Fire Department and King County Fire Protection District #26 formally becoming “South King Fire and Rescue”. The Strategic Planning process continued to be a guiding force during 2006; however, the vast majority of the year was spent on melding the cultures, equipment, policies, procedures, training, and other necessary projects and processes to ensure the merger was a complete and verifiable success for the department and citizens we serve. And, it has been!!!

In addition, a “Top 10” list was created to ensure that the ten (10) most important objectives, as determined by the Strategic Planning Team itself, would be given the primary focus during 2006 and 2007. These objectives have been worked on during 2006, with a goal of bringing them to fruition during 2007.

Top 10 List for 2006/2007

The following objectives have been identified by the Strategic Leadership Planning Team as the “Top Ten” issues of significance for 2006 and 2007. These are the key items from our Strategic Leadership Plan that our team, and our other department personnel, should work on with the goal of bringing each to resolution within the next year or so. The team leaders are identified together with team members, which can be added to from the ranks of our very talented employee base.

Human Resource Objectives:

- 1) **HR Action Step #2: The Administration and Labor should work together in analyzing alternative health care options for all personnel.**

 Team Leaders: Chief Al Church
 Union President/Captain Gordie Olson

 Team Members: WSCFF/Captain Rick Chaney

- 2) **HR Action Step #5: An improved process of targeting, recruiting and potentially hiring a more diverse workforce shall be developed and implemented. This could include a “Prospective Firefighter Orientation Day”, coordination with the military’s transition**

assistance team, as well as a South King Fire and Rescue “Recruitment Team”.

Team Leaders: PEO Donna Conner
FF Nick Spaeder
Union President/Captain Gordie Olson

Team Members: D/C Vic Pennington
Lt. Jerry Clos
WSCFF/Captain Rick Chaney

- 3) HR Action Step #6: The current performance assessment/evaluation system should be revisited to ensure it is meeting the needs of the department and our personnel’s growth.**

Team Leaders: A/C Pat Kettenring
PEO Donna Conner
FF Shane Smith

Team Members: Union Vice President/Captain Bob Stinnett
B/C Steve Trackwell
Lt. Gregg Bordner

Integrated Operations Objectives:

- 4) Operations Action Step #2: A team shall be developed to begin evaluating response data to determine compliance/non-compliance with the requirements of NFPA 1710. The team shall make recommendations to the Administration and labor related to NFPA 1710 objectives not being met, if any. In addition, a cost analysis of meeting NFPA response standards, as well as meeting the objective of reaching a staffing level of four (4) on all front line engine companies, shall be developed. (In addition, this team shall explore the potential of relocating the ladder truck; purchasing quint apparatus and locating it strategically with a bond issue; and other strategic movement of apparatus/personnel to meet the community needs.)**

Team Leaders: A/C Pat Kettenring
FF Shane Smith

Team Members: D/C Mike Knorr
Lt. Chris Murphy
Lt. Gregg Bordner
Union President/Captain Gordie Olson
Union Secretary/Lt. Ryan Herrera
D/C Jerry Thorson
Lt. Kevin Crossen

- 5) **Operations Action Step #3:** The Board of Commissioners and Administration shall research and consider a RFP (Request for Proposal) related to ambulance transports from the private sector to improve ambulance response times in our service area. The RFP should consider penalties for long response times, as well as a voucher program for cab/taxi transportation to emergency rooms as opposed to utilizing ambulances or fire department aid cars for certain non-emergent patients.

Team Leaders: A/C Ed Plumlee
Lt. Pat Soper
Union President/Captain Gordie Olson

Team Members: Lt. Gregg Bordner
Chief Al Church

- 6) **Operations Action Step #7:** A team shall be assembled to research the need and viability of a 24-hour “Safety Officer” (i.e. a 2nd Chief Officer toned out to all incidents, or some other means of providing this level of safety and accountability...such as the addition of a Coordinating Captain position).

Team Leaders: A/C Pat Kettenring
B/C Steve Trackwell
Union President/Captain Gordie Olson

Team Members: Union Treasurer/Lt. Joel Barrett
Union Vice President/Captain Bob Stinnett
Lt. Kevin Crossen

Leadership Objectives:

- 7) **Leadership Action Step #2:** The Administration and labor shall appoint members to work on a team with their assigned goal being the establishment of an Officer Development program that links into the department’s promotional process. This process shall have an additional goal of assisting in the future transition of department personnel into the ranks of middle management (Lieutenants and Captains) and upper management (all applicable Chief Officer positions).

Team Leaders: A/C Ed Plumlee
D/C Vic Pennington
WSCFF/Captain Rick Chaney

Team Members: Union Secretary/Lt. Ryan Herrera
FF Wendy Chinn

Lt. Jerry Clos
B/C Chuck Kahler
Lt. Chris Murphy
Lt. Gregg Bordner

- 8) **Leadership Action Step #4: The Administration and Labor shall finalize and implement a communications model to improve the sharing of information within the department (i.e. numbered memos, written policies, newsletters, and all form of communications shall be revisited).**

Team Leaders: Lt. Kevin Crossen
Union Secretary/Lt. Ryan Herrera

Team Members: FF Nick Spaeder
PEO Kirsti Weaver

Finance Objectives:

- 9) **Finance Action Step #1: The Board of Commissioners, the Administration and Labor shall meet to discuss potential funding options for South King Fire and Rescue's future, with the goal of consensus on our fiscal direction.**

Team Leaders: Chief Al Church

Team Members: D/C Mike Knorr
D/C Vic Pennington
Union President/Captain Gordie Olson

- 10) **Finance Action Step #2: The Board of Fire Commissioners and Administration shall establish a list of funding options for capital purchases which includes various revenue sources appropriate to the project. Examples could include different sources of revenue and financing packages depending upon the specific project (i.e. voter approved bonds, GO bonds, excess levy, grants, etc.). The Board of Commissioners and Administration shall monitor on an ongoing basis the capital reserve fund to determine that the fund balances and listed equipment are reasonable and prudent.**

Team Leaders: Chief Al Church

Team Members: D/C Vic Pennington
D/C Jerry Thorson
B/C Steve Trackwell
Union Treasurer/Lt. Joel Barrett
D/C Mike Knorr
Union Vice President/Captain Bob Stinnett

In addition to establishing the Top 10 list and working on the successful merger projects and processes, the following objectives were completed during 2006:

Human Resource Goals Completed

- a. Stations #62 and #64 need to be evaluated related to space considerations for physical fitness equipment tied into the “wellness/fitness” initiative in place within the department.
 - Station #62 and #64 had their workout areas modified to provide additional space for wellness/fitness equipment.

Integrated Operations Goals Completed

- a. All Integrated Operations Goals for 2006 were directly linked into making the merger of the Federal Way Fire Department and King County Fire Protection District #26 a success as “South King Fire and Rescue”.
 - All goals and objectives during 2006 had a direct linkage to the successful merger of KCFPD #26 and the Federal Way Fire Department. Training programs, staffing considerations, financial programs, everything had something to do with the merger and the full year in the merged environment.

Community Goals Completed

- a. A program shall be developed to coordinate the annual reporting requirements of HB 1756, which has been codified within RCW 52.33.
 - The Board of Commissioners adopted a resolution which incorporated the response standards as required by HB 1756/RCW 52.33. In 2007, the Annual report for South King Fire and Rescue shall include a comparison of actual response times with the adopted standards as required by law. South King Fire and Rescue will be one of the first departments in the State to meet this requirement.
- b. Adding one Deputy Fire Marshal to assist with the workload in prevention, and to provide training for operations division personnel.

- A new Deputy Fire Marshal position was budgeted for in the fall of 2006, and will be implemented in March of 2007.
- c. Exploring opportunities to support the Citizen Corps, related to Homeland Security, as it may develop in the communities we serve.
 - The Public Education Division has created a volunteer cadre of citizens, formed under the Citizens Corps program, to assist with instructing our diverse community with prevention and health related programs.
- d. South King Fire and Rescue shall take a leadership role related to Emergency Management and Disaster Preparation within the communities we serve. This leadership role shall include, among other things:
 1. Updating disaster plans.
 2. Developing a pandemic flu plan.
 3. Analyzing station needs related to food, water, and fuel for an extended period of time during a disaster (i.e. 9 days worth of supplies and fuel with adequate generator power).
 - South King Fire and Rescue initiated our own Emergency Manager position in the form of a Deputy Chief during 2006. The new Emergency Manager is working directly with the City of Federal Way, the City of Des Moines, King County, and the other Zone 3 agencies to ensure our disaster plans and EOC operations are ready for any potential incident. In addition, 2006 saw the addition of the WebEOC program, currently being implemented in our fire department to assist with major disaster scenarios.

Financial Goals Completed

- a. South King Fire and Rescue successfully passed a Lid Lift for the 6th year in a row.
 - As the objective states, the lid lift was successful for the 6th straight year in Federal Way and Des Moines.
- b. South King Fire and Rescue was very involved in the 2006 Legislative Process, working towards securing a multi-year lid lift process. 2007 looks to be the potential

year for successful passage of this required change in the law to allow multi-year lid lifts.

- The Board of Commissioners and the Fire Chief/Administrator were directly involved in the 2006 Legislative process. The Fire Chief/Administrator holds the position as Chair of the Washington Fire Chiefs Legislative Committee, and participated in the development of and testimony for numerous bills of importance to the fire department and citizens we serve. This involvement will continue in 2007.
- c. The Administration and Board of Commissioners of South King Fire and Rescue shall be involved in the process related to the development of a plan for the 2007 EMS Levy. Emphasis shall be placed on ensuring that ALS and BLS issues are identified, funded and coordinated to meet the needs of the Federal Way and Des Moines communities. (NOTE: It should be noted that due to the ongoing efforts between South King Fire and Rescue and King County EMS, that a new paramedic unit, Medic #13, was staffed at Station #26 during 2006. This provides the citizens of South King Fire and Rescue with 2 medic units and 1 MSO located within the fire district itself).
- The Board of Commissioners, Fire Chief/Administrator and the Assistant Chief of EMS remain involved in the process of development and support for the 2007 EMS Levy, which will be on the ballot in November of 2007.

SOUTH KING FIRE & RESCUE

MASTER STRATEGIC LEADERSHIP TEAM WORK PRODUCT 2007

This section will be updated on an annual basis to contain a list of the goals and operational action items which have been completed, or that have been eliminated from any further consideration.

2007 Successes

The Strategic Planning process continues to be a guiding force during 2007. Legislative successes, coupled with our Strategic Planning efforts, continue to move the fire department forward in many areas.

In addition, the “Top 10” list was updated in July of 2007 and once again in December of 2007 to ensure that the ten (10) most important objectives, as determined by the Strategic Planning Team itself, would be given the primary focus during the balance of 2007 and heading into 2008.

Finally, a SWOTT (Strengths, Weaknesses, Opportunities, Threats and Trends) Analysis was conducted by the Strategic Planning Team in December of 2007, with the focus on the years 2008 through 2013. The following represents the results of the SWOTT analysis, followed by the updated “Top 10 List for 2007/2008”.

SWOTT

Strengths

- Stable funding for six (6) years
- Connections with communities, locally and regionally...as well as at the state level
- New staffing in the Training Division
- High quality of people in department that can be mentors
- TAG and the work they are doing
- Prevention programs we have in place
- Communication with Des Moines Police Department
- Development in Emergency Management with both cities
- Joint Labor/Management relationship
- We did the merger well
- Top notch internal investigations
- Our Strategic Planning process

Weaknesses

- Seeing less and less significant emergency incidents = less field experience
- Huge turnover in Chief and Officers over next 5-10 years
- Succession plan/Officer development plan
- Having a rated Officer on the Aid Car as opposed to the Engine Company (i.e. allow Firefighters more acting time on Aid Car)

- Patient transports...potentially not providing best patient care by using privates (instead of handling our own transport)
- Public perception that the fire department should transport
- Communication with Federal Way Police Department
- Lack of fire flow in Water District #54 and at the Marina
- Crew continuity/positional assignments...(i.e. could work to improve continuity to improve consistency)
- Lack of a staffed ladder truck
- Lack of ability to conduct full scale arson investigations
- Documentation on all processes

Opportunities

- Can do good mentoring, customized to our new leaders in the department
- Opportunity to put funds towards future leaders
- More neighborhood meetings to share information and educate the communities
- Build mentoring through JATC
- Build relationship with Auburn and Federal Way Police Departments
- Restructure due to Accreditation/Deccan studies and “Standards of Cover” related to station/staffing allocation
- Continue to utilize the special skills of our personnel
- Delivery methodologies for our next generation of new hires
- Receive a Class 2 in Des Moines
- Being able to deal with high rises
- “Potential merger” opportunities
- Continue with our annual “Peanut Butter & Jelly and Bacon & Egg: circuit
- Invite City managers and Police Chiefs to our Commissioners meetings
- Tiered opticom system
- Dispatch AVL
- RMS & crystal reports
- Data management...more help in Information Systems
- ALS in the fire service
- Regional training center

Threats/Trends

- Social work type of calls and how to deal with it
- Evaluation of salary/benefits costs related o medical costs and exposure in the future
- Illness and disabilities in work force = aging work force
- Other agencies reducing services that impacts FD (i.e. reduction in juvenile fire setter program)
- Keep an eye on what our citizens expect from us
- Changing skyline in Federal Way & Des Moines
- More adult family homes with aging population = more calls

- Threats to our funding sources
- Change in work scheduled
- ALS in the fire service
- Trend of cancer in fire service

Top 10 List for 2007/2008

The following objectives have been identified by the Strategic Leadership Planning Team as the “Top Ten” issues of significance for the balance of 2007 and heading into 2008. These are the key items from our Strategic Leadership Plan that our team, and our other department personnel, should work on with the goal of bringing each to resolution within the next year or so. The team leaders are identified together with team members, which can be added to from the ranks of our very talented employee base.

Human Resource Objectives:

- 1) **HR Action Step #2: The Administration and Labor should work together in analyzing alternative health care options for all personnel.**

Team Leaders: Chief Al Church
Union President/Lt. Ryan Herrera
HR Administrator Mary Stevens

Team Members: B/C Rick Chaney
B/C Gordie Olson
D/C Mike Knorr
Union Treasurer/Lt. Joel Barrett
Commissioner Jerry Harris

NOTE: This objective was completed in 2008 with the advent of a committee to research the HRA medical plan option for 2010 or later.

- 2) **HR Action Step #5: An improved process of targeting, recruiting and potentially hiring a more diverse workforce shall be developed and implemented. This could include a “Prospective Firefighter Orientation Day”, coordination with the military’s transition assistance team, as well as a South King Fire and Rescue “Recruitment Team”.**

Team Leaders: HR Administrator Mary Stevens
PEO Donna Conner
FF Nick Spaeder
Union President/Lt. Ryan Herrera

Team Members: D/C Vic Pennington
Lt. Jerry Clos
B/C Rick Chaney
B/C Gordie Olson
FF Wendy Chinn
Capt. Alex Charoni

NOTE: This objective has been initiated and will be ongoing.

Integrated Operations Objectives:

- 3) **Operations Action Step #2: A team shall be developed to begin evaluating response data to determine compliance/non-compliance with the requirements of NFPA 1710. The team shall make recommendations to the Administration and Labor related to NFPA 1710 objectives not being met, if any. In addition, a cost analysis of meeting NFPA response standards, as well as meeting the objective of reaching a staffing level of four (4) on all front line engine companies, shall be developed. (In addition, this team shall explore the potential of relocating the ladder truck; purchasing quint apparatus and locating it strategically with a bond issue; and other strategic movement of apparatus/personnel to meet the communities' needs.)**

Team Leaders: A/C Ed Plumlee
FF Shane Smith

Team Members: D/C Mike Knorr
Lt. Chris Murphy
Lt. Gregg Bordner
B/C Gordie Olson
Union President/Lt. Ryan Herrera
D/C Jerry Thorson
Capt. Kevin Crossen
Union Treasurer/Lt. Joel Barrett
Capt. Kevin Body

NOTE: This has been initiated and will be ongoing.

- 4) **Operations Action Step #3: A team of employees shall be established to address the surface water/ice rescue problem, and make recommendations to the Administration and Labor.**

Team Leaders: A/C Ed Plumlee
B/C Steve Trackwell
FF Nick Spaeder
FF Shane Smith

Team Members: Capt. Dave Mataftin

Capt. Alex Charoni
Lt. Pat Soper
Union President/Lt. Ryan Herrera
Capt. Kevin Body

NOTE: Policies, procedures and training are in place for this objective. Progress will continue during 2009/2010.

Leadership Objectives:

- 5) **Leadership Action Step #2: The Administration and Labor shall appoint members to work on a team with their assigned goal being the establishment of an Officer Development program that links into the department's promotional process. This process shall have an additional goal of assisting in the future transition of department personnel into the ranks of middle management (Lieutenants and Captains) and upper management (all applicable Chief Officer positions).**

Team Leaders: A/C Ed Plumlee
D/C Vic Pennington
B/C Rick Chaney

Team Members: Union President/Lt. Ryan Herrera
FF Wendy Chinn
Lt. Jerry Clos
B/C Chuck Kahler
Lt. Chris Murphy
Lt. Gregg Bordner
B/C Gordie Olson
HR Administrator Mary Stevens
Capt. Kevin Body

NOTE: A great deal of progress has been made on this objective, with more work to come in 2009 and beyond.

- 6) **Leadership Action Step #4: The Administration and Labor shall finalize and implement a communications model to improve the sharing of information within the department (i.e. numbered memos, written policies, newsletters, and all forms of communication shall be revisited).**

Team Leaders: Capt. Kevin Crossen
Union President/Lt. Ryan Herrera

Team Members: IT Director Joe Ganem
FF Nick Spaeder
PEO Kirsti Weaver

Lt. Steve Hopf
Lt. Jeff Bellinghausen

NOTE: This will be revisited in 2009/2010.

- 7) **Leadership Action Step/New Issue: A team shall be assembled to research and analyze overall organizational risk management as applied to required training and departmental policies.**

Team Leaders: HR Administrator Mary Stevens
D/C Vic Pennington

Team Members: B/C Rick Chaney
A/C Ed Plumlee

NOTE: This objective will be ongoing and reflected in our training.

- 8) **Leadership Action Step/New Issue: A team shall be assembled to ensure that the overall departmental “career development plan” is linked into the Officer Development program, to include educational plans and funding requirements with linkage into JATC where applicable.**

Team Leaders: B/C Rick Chaney
Capt. Alex Charoni

Team Members: B/C Gordie Olson
HR Administrator Mary Stevens
Capt. Kevin Crossen
Union President/Lt. Ryan Herrera
Union Treasurer/Lt. Joel Barrett
Lt. Chris Murphy
Lt. Jerry Clos
Lt. Gregg Bordner
D/C Vic Pennington

NOTE: A great deal of effort has been done on this objective, with more efforts to come in 2009/2010.

Finance Objectives:

- 9) **Finance Action Step #2: The Board of Fire Commissioners and Administration shall establish a list of funding options for capital purchases which includes various revenue sources appropriate to the project. Examples could include different sources of revenue and financing packages depending upon the specific project (i.e. voter approved bonds, GO bonds, excess levy, grants, etc.). Linkage for**

future capital purchases shall include a proposal for a 2010 bond issue.

Team Leaders: Chief Al Church
CFO Lawson

Team Members: D/C Mike Knorr
Union President/Lt. Ryan Herrera
Union Vice President/Captain Bob Stinnett
B/C Rick Chaney
Union Treasurer/Lt. Joel Barrett
Capt. Kevin Crossen
Lauri Perry
FF Scott Ervin
Capt. Kevin Body

NOTE: This has been completed with the ultimate goal being a 2010 bond issue.

- 10) **A team shall be assembled to review departmental response times and to make recommendations related to staffing deployment, station locations, apparatus assignments, and shall prepare a complete “Standards of Cover” document for South King Fire & Rescue.**

Team Leaders: Chief Church
A/C Ed Plumlee
D/C Mike Knorr

Team Members: B/C Chuck Kahler
B/C Gordie Olson
B/C Rick Chaney
B/C Steve Trackwell
D/C Vic Pennington
Union President/Lt. Ryan Herrera
D/C Ron Biesold

NOTE: This will be an objective for 2009/2010.

In addition to establishing the Top 10 list and working on the successful merger projects and processes, the following objectives were completed during 2007:

***Human Resource Goals Completed
None to date (July of 2007)***

Integrated Operations Goals Completed

- a. Strong consideration should be given to a RFP (request for proposal) related to ambulance transports from the private sector to improve ambulance response times in our service area.
 - Sole source negotiations took place which resulted in a contract for ambulance service with AMR (American Medical Response), which mandates response times coupled with liquidated damages for long responses. The contract also includes quality assurance provisions to ensure a high level of response is maintained for our citizens.
- b. A team shall be assembled to research the need and viability of a 24-hour “Safety Officer” (i.e. a 2nd Chief Officer toned out to all incidents or some other means of providing this level of safety and accountability).
 - The team recommended utilizing the “Duty Chief” and a full “Chief’s Call back” (as necessary) to ensure that a Safety Officer is provided at necessary emergency incidents.
- c. Reduce the impact of administrative paperwork and duties on the shift Battalion Chiefs by considering a Coordinating Captain, or Administrative Battalion Chief position, on day-shift, thus allowing them to spend more time with their assigned personnel to train, drill, conduct pre-fire plans, mentor, and improve the overall cohesiveness of the response crews.
 - A daytime “Administrative Battalion Chief” position has been approved to be filled in the winter of 2007, the goal being to free up the Operations Battalion Chiefs to coach and mentor their officers on a more regular basis.

Leadership Goals Completed

- a. A process/system needs to be developed which will assist the Battalion Chiefs in spending more time mentoring their assigned Officers, relieving them of certain administrative duties and/or paperwork.
 - As per above, a daytime “Administrative Battalion Chief” will be filled in the winter of 2007 to meet this goal as approved by the Board of Fire Commissioners.

Community Goals Completed
None to date (July of 2007)

Financial Goals Completed

- a. Work with the legislature to ensure that funding is maintained or improved for junior taxing districts (e.g. passage of a bill to allow Lid Lifts to last for 6 years at a time, or multi-year Lid Lifts lasting longer than 1 year.
 - In 2007, the department worked to ensure the passage of Senate Bill 5498...which allows for multi-year lid lifts for junior taxing districts (including fire districts) for up to 6 years in a row. This was signed by the Governor on May 8th, 2007, and became law on July 22nd, 2007.
- b. The service benefit charge should be considered for future funding, as it provides for 6 years worth of revenues after one ballot measure passes.
 - The benefit charge methodology of funding was analyzed in April and May of 2007 for potential application in the fire district.
- c. The Board of Fire Commissioners, the Administration and Labor shall meet to discuss potential funding options for South King Fire and Rescue's future, with the goal of consensus on our fiscal direction.
 - The Board of Fire Commissioners, the Administrative team and Labor met to discuss the options of a multi-year lid lift, an excess levy and the benefit charge methodologies for funding the department.
 - The funding methodology of choice was determined to be a multi-year lid lift, to be placed on the ballot in August of 2007 for implementation in 2008 through 2013...with a potential bond issue to cover capital needs targeted for 2010.

SOUTH KING FIRE & RESCUE

MASTER STRATEGIC LEADERSHIP TEAM WORK PRODUCT 2008

This section will be updated on an annual basis to contain a list of the goals and operational action items which have been completed, or that have been eliminated from any further consideration.

2008-A Direction to a Bond Issue

A major focus heading into 2008, and linked in with all Strategic Leadership Plan goals and objectives, is the work on the proposed 2009 or 2010 bond issue. This bond issue will dramatically change the face of South King Fire & Rescue and the services we provide.

The following reflects the work groups assigned in April of 2008 to initiate the bond issue work product:

Group #1 – Training Center/Wellness Facility

Team Leaders: D/C Mike Knorr
D/C Vic Pennington

Team Members: A/C Ed Plumlee
B/C Rick Chaney
Lt. Steve Hopf
Capt. Kevin Body
Union Vice President/Capt. Bob Stinnett
DFM Chris Ingham
Lt. Gregg Bordner
Union Secretary/Lt. Scott Ervin
FF Anthony Johns
Yvette Dominguez
Lt. Jeff Bellinghausen
FF Todd Williams

Group #2 – Aerial (s)

Team Leaders: B/C Chuck Kahler
B/C Gordie Olson
B/C Rick Chaney

Team Members: Lt. Pat Soper
FF Shane Smith
Capt. Alex Charoni
FF Mike D. Lawson
FF Roy Smith
Steve Denton
Lt. Chris Murphy
Lt. Jeff Bellinghausen

Group #3 – Stations 66 (move), 67, 69 & Property

Team Leaders: Chief Al Church
D/C Mike Knorr

Team Members: Union Treasurer/Lt. Joel Barrett
D/C Jerry Thorson
Lauri Perry
DFM Chris Ingham
Capt. Kevin Crossen
Capt. Alex Charoni
Lt. Jerry Clos
Lt. Gregg Bordner
Union Treasurer/Lt. Scott Ervin
Commissioner Gates

Group #4 – Fleet/Facilities and Central Storage

Team Leaders: Chief Al Church
D/C Mike Knorr

Team Members: DFM Chris Ingham
Capt. Kevin Crossen
FF Roy Smith
Commissioner Hershey
FF Todd Williams

Group #5 – Fire Boat

Team Leader: B/C Steve Trackwell

Team Members: D/C Jerry Thorson
FF Nick Spaeder
PEO Donna Conner
Lt. Jerry Clos
Capt. Dave Mataftin
Steve Denton

Group #6 – Critical Communications (MDC's, AVL, Portables, etc)

Team Leaders: IT Director Joe Ganem
D/C Ron Biesold

Team Members: Union Treasurer/Lt. Joel Barrett
D/C Vic Pennington
B/C Chuck Kahler
Lt. Steve Hopf
Capt. Kevin Crossen
FF Todd Williams

Group #7 – Rescue/Special Ops Rig

Team Leaders: A/C Ed Plumlee
B/C Steve Trackwell

Team Members: D/C Vic Pennington
B/C Gordie Olson

Lt. Pat Soper
FF Anthony Johns
FF Shane Smith
Capt. Alex Charoni
PEO Kirsti Weaver
Steve Denton
FF Roy Smith

Group #8 –Administrative Offices

Team Leaders: Chief Church
D/C Mike Knorr
D/C Jerry Thorson

Team Members: B/C Steve Trackwell
Lauri Perry
HR Administrator Mary Stevens
IT Director Joe Ganem

Group #9 – Bond/Oversight/Old DM Bond/Contingency/Timing

Team Leaders: Chief Church
A/C Ed Plumlee
CFO Dave Lawson

Team Members: PEO Kendra Kay
Commissioner Hershey
Commissioner Gates
Union President/Lt. Ryan Herrera
Lt. Steve Hopf
PEO Donna Conner

A Vision for the Future

In addition to the aforementioned bond efforts, the April of 2008 Strategic Leadership Planning Team met and discussed a long term “vision” for the future of South King Fire & Rescue. Initially, Chief Church shared his “vision” for the next 10 years (2008 through 2018). His vision looks like this:

By 2018, South King Fire & Rescue will:

- **BE ACCREDITED...and will actually be working on our 2nd or 3rd re-accreditation processes. In addition, our SLP will be alive and well!!!**
- **Cover Federal Way, Des Moines, and Burien as one merged department serving nearly 200,000 citizens.**
- **Be operating out of 12 staffed stations with two (2) tillered-quints staffed with 4-personnel each. The stations include 3 in Burien (incorporating one new Burien station); 2 in Des Moines; and 7 in Federal Way/unincorporated King County (including two new stations...one south and one central). This will include staffed aid cars at Stations #26, #62, #63, #64 and #28 (a minimum of 5 staffed aid cars).**
- **Have two (2) Battalions (North and South)...with two (2) Battalion Chiefs on duty 24/7/365.**
- **Have worked with the City of Des Moines and the old WD #54 to have all fire flows meet/exceed national standards and be provided by entity (i.e. Highline Water).**
- **Have initiated a Fire Investigation program in cooperation with Kent and VRFA for our service area. This includes a minimum of 2-SKF&R Investigators with limited/reserve commissions.**
- **Have a state-of-the-art Fire Boat providing necessary fire flows and rescue capability within Puget Sound.**
- **Have achieved Class 2 ratings in Federal Way, Des Moines and Burien.**
- **Be a co-manager/provider of ALS service with other partners in South King County employing firefighter paramedics (possibly via a Fire Authority concept with partners including Kent, Renton and possibly VRFA).**
- **Have achieved a residential sprinkler ordinance for all new construction in our service area.**

- **Have a state-of-the-art Training Center located centrally in the District.**
- **Have a state-of-the-art Fleet and Facilities shop co-operated with the City of Federal Way and the Federal Way School District, which meets/exceeds national standards for certifications.**
- **Have community programs in place, supported by our Public Education Division and Operations staff, which significantly reduce the number of residential fires, and promotes healthy lifestyles without the need to call 9-1-1 for social services.**
- **Have a community response team in place to manage non-emergent EMS responses.**
- **Have a workforce that is well educated with a succession plan in place for our future leadership.**
- **Be considered a political stronghold in South King County (both regionally and Statewide).**
- **Have Labor-Management relations which are recognized as the benchmark of excellence for the fire service.**
- **Begin work towards a 20 year vision wherein South King Fire and Kent Fire could merge to become one department, eventually leading towards a true “South King Fire & Rescue” covering all of Zone 3 (all south King County fire departments).**
- **Finally.....Chief Church will retire on September 2nd, 2018 (if he makes it that long) with 40 years and 1 day of service to the community.**

Following his vision, all participants divided up and came to consensus on *their vision* for the future of the fire department. There were many commonalities between all the members of the Strategic Leadership Team related to their vision of the future, which bodes well for a strong planning effort over the next 10 to 20 years with employees involved at all points along the way.

The following are highlights from the different group’s “visions for our future”:

Group 1 - 10 Year Plan

- I. New forms of funding
 - a. EMS (Emergency Medical Services) Levy
 - b. AV (Assessed Value) @ \$1.50
 - c. Mitigation Fees
- II. Capital Replacement Schedule
 - a. Rigs (reduce years of service)
 - b. Facilities – Major Renovations
- III. EMS (Emergency Medical Services) Call Management
 - a. Valley Communications
 - b. Service Responses
- IV. Fire Based - ALS (Advanced Life Support)
- V. Increase Staff on certain rigs
- VI. Staffed Ladders/Quints
 - a. Three (3) people minimum
 - b. Not cross staffed
- VII. Increase Operations staff
 - a. New stations
 - b. Support staff
- VIII. New Technology
 - a. Vehicles
 - b. Firefighting equipment
 - c. Public Education
- IX. Continue to be regional leaders
- X. Retirement Incentive
 - a. Medical
 - b. Fill the gap
 - c. Wellness/Injury prevention
- XI. Officer Development
 - a. Degrees
 - b. JATC

Group 1 - 20 Year Plan – A Regional Fire Department

- 4 person companies
- BLS/ALS Transporting
- Sprinklers 100% retro

Group 2 - 10 Year Plan

- I. Employees
 - a. Diversity
 - b. Hiring & Training
 - c. Recruiting
 - d. Day 1 – Retirement & Financial planning (include the spouse)

- II. Fitness ∅ HTN ∅ HRT ∅ Tobacco
 - a. Retirement issues & Realistic options
 - b. Health Care Benefits

- III. Department Expansion
 - a. Dash Point
 - b. Current 68
 - c. Browns Pt.
 - d. Class I – Insurance Rating
 - e. South County Fire Department

- IV. Response
 - a. Four (4) person engines
 - b. Staffed ladder trucks

- V. Prevention
 - a. Inspections by FMO
 - b. Pre-fire inspections by companies
 - c. Full time mapping personnel – pre-fire drawings
 - d. Two (2) Fire Marshals – One (1) North/One (1) South
 - e. Presence at all cities
 - f. South County Investigations

- VI. Training - Academy
 - a. Succession from start
 - b. Education, Training, Certification all tied together
 - c. Full time coordinator
 - d. Expanded simulator program

- VII. Regional
 - a. Special ops consolidated training
 - b. Zone 3 USAR
 - c. Marine – Surface Water/Lakes

- VIII. Emergency Management
 - a. Terrorist activities will drive special ops
 - b. Integrate military, state, schools resources for quick first response

- IX. Community
 - a. Health Services
 - b. Non-priority response model
 - Dispatch protocol
 - c. New EMS ALS
 - Deployment Model
- X. Funding
 - a. Long term stable
 - b. Grants
 - c. SBC (Service Benefit Charge)
- XI. Support staff throughout the organization

Group 2 - 20 Year Plan (2028)

Chief Church to retire with 50 years + 1 day

Group 3 - 10 Year Plan

- I. Staffing
 - a. Four (4) person Engine Companies
 - b. Two (2) Staffed Ladder Trucks (Tilered/Aerials)
 - c. Fire Prevention to do all Inspections
- II. Special Operations
 - a. Minimum Staffing for Special Operations
 - b. Centralized Heavy Rescue Unit
 - c. Create Specialty Stations
 - d. Surface Water Rescue/Dive Team - Fresh and Saltwater
- III. Centralized Offices/Training Station

Group 4 - 10 Year Plan

- I. Increase staffing to 62
 - a. 12 Stations
 - b. 12 Engines – 3 personnel on each Engine
 - c. 2 Ladders (Quints) – 4 personnel on each Ladder
 - d. 5 Aid Units – 2 personnel on each Aid Unit
 - e. 3 Medic Units – 2 paramedics on each Medic Unit
 - f. 2 Battalion Chiefs – 1 North/1 South
 - g. 1 Fire Boat
 - h. 1 HazMat Unit
 - i. 1 Rescue Unit
- } cross staffed

North Battalion

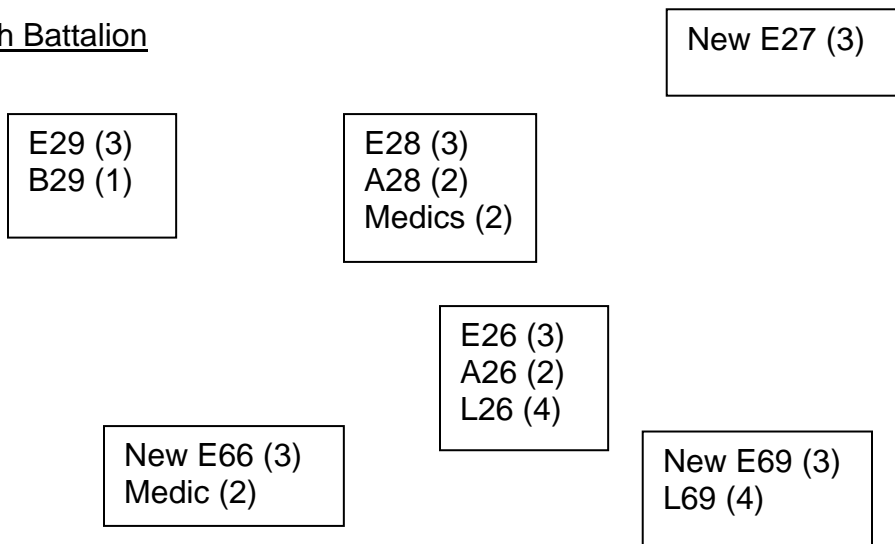

South Battalion

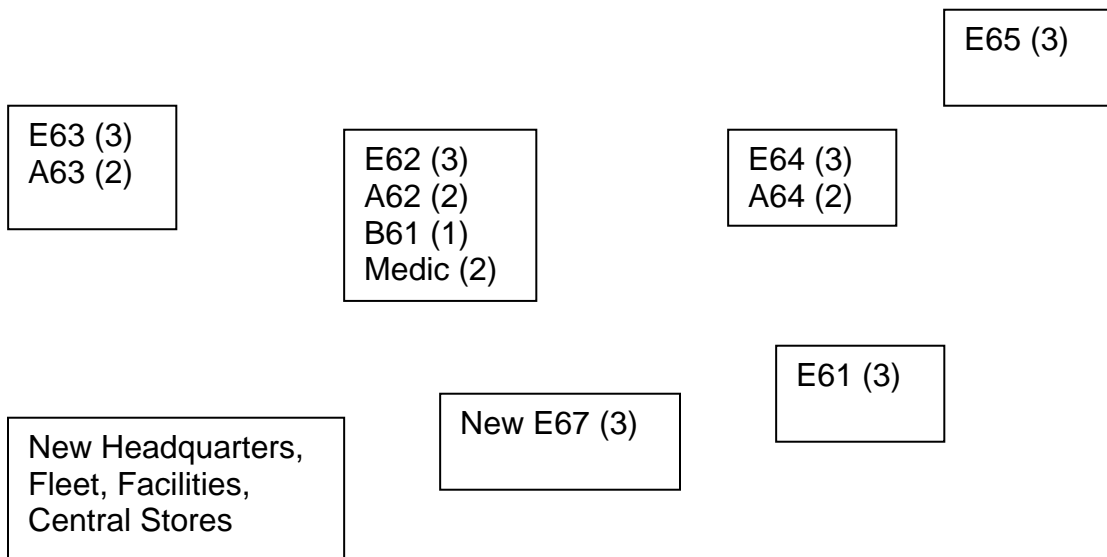

- II. 62 personnel total per shift
- III. Mergers
 - a. We agree 😊
- I. Services Provided
 - a. ALS
 - b. Battalion Aide
 - Phoenix Red Shirt Model
 - c. We do our own recruitment, hiring, and academy
 - d. CRT
- II. Personnel Development
 - a. Continue Officer Development
 - b. B/C Driver/Aide
 - c. Continue Specialty Position Development
 - Engineer
 - Safety Officer
 - Truck Company
 - Special Teams
 - d. Specified Career Paths from FF to Chief
- III. Community Development
 - a. Maintain our current programs
 - b. Professional, aggressive education to those needing social services, more than E911 services
- IV. Misc.
 - a. Remove dispatch barrier with Tacoma
 - b. Be willing to change for the better
 - Technology
 - Apparatus
 - Equipment

All-in-all.....all members of the Strategic Leadership Planning Team have a vision for the future (with many sharing common goals and a common vision), and are willing to share and work on projects to help us all accomplish an agreed upon vision to enhance and improve our department and level of service to the citizens we serve.

2008 “Top 10” List Outcomes

The following represents the 2008 outcomes related to the Top 10 objectives identified by the Strategic Leadership Planning Committee:

Human Resource Objectives:

- 1) **HR Action Step #2:** The Administration and Labor should work together in analyzing alternative health care options for all personnel.
NOTE: This objective was completed in 2008 with the advent of a committee to research the HRA medical plan option for 2010 or later.

- 2) **HR Action Step #5:** An improved process of targeting, recruiting and potentially hiring a more diverse workforce shall be developed and implemented. This could include a “Prospective Firefighter Orientation Day”, coordination with the military’s transition assistance team, as well as a South King Fire and Rescue “Recruitment Team”.
NOTE: This objective has been initiated and will be ongoing.

Integrated Operations Objectives:

- 3) **Operations Action Step #2:** A team shall be developed to begin evaluating response data to determine compliance/non-compliance with the requirements of NFPA 1710. The team shall make recommendations to the Administration and Labor related to NFPA 1710 objectives not being met, if any. In addition, a cost analysis of meeting NFPA response standards, as well as meeting the objective of reaching a staffing level of four (4) on all front line engine companies, shall be developed. (In addition, this team shall explore the potential of relocating the ladder truck; purchasing quint apparatus and locating it strategically with a bond issue; and other strategic movement of apparatus/personnel to meet the communities’ needs.)
NOTE: This has been initiated and will be ongoing.

- 4) **Operations Action Step #3:** A team of employees shall be established to address the surface water/ice rescue problem, and make recommendations to the Administration and Labor.
NOTE: Policies, procedures and training are in place for this objective. Progress will continue during 2009/2010.

Leadership Objectives:

- 5) **Leadership Action Step #2:** The Administration and Labor shall appoint members to work on a team with their assigned goal being

the establishment of an Officer Development program that links into the department's promotional process. This process shall have an additional goal of assisting in the future transition of department personnel into the ranks of middle management (Lieutenants and Captains) and upper management (all applicable Chief Officer positions).

NOTE: A great deal of progress has been made on this objective, with more work to come in 2009 and beyond.

- 6) **Leadership Action Step #4:** The Administration and Labor shall finalize and implement a communications model to improve the sharing of information within the department (i.e. numbered memos, written policies, newsletters, and all forms of communication shall be revisited).

NOTE: This will be revisited in 2009/2010.

- 7) **Leadership Action Step/New Issue:** A team shall be assembled to research and analyze overall organizational risk management as applied to required training and departmental policies.

NOTE: This objective will be ongoing and reflected in our training.

- 8) **Leadership Action Step/New Issue:** A team shall be assembled to ensure that the overall departmental "career development plan" is linked into the Officer Development program, to include educational plans and funding requirements with linkage into JATC where applicable.

NOTE: A great deal of effort has been done on this objective, with more efforts to come in 2009/2010.

Finance Objectives:

- 9) **Finance Action Step #2:** The Board of Fire Commissioners and Administration shall establish a list of funding options for capital purchases which includes various revenue sources appropriate to the project. Examples could include different sources of revenue and financing packages depending upon the specific project (i.e. voter approved bonds, GO bonds, excess levy, grants, etc.). Linkage for future capital purchases shall include a proposal for a 2010 bond issue.

NOTE: This has been completed with the ultimate goal being a 2010 bond issue.

- 10) A team shall be assembled to review departmental response times and to make recommendations related to staffing deployment, station locations, apparatus assignments, and shall prepare a complete "Standards of Cover" document for South King Fire & Rescue.

NOTE: This will be an objective for 2009/2010.

SOUTH KING FIRE & RESCUE

MASTER STRATEGIC
LEADERSHIP TEAM
WORK PRODUCT
2009

This section will be updated on an annual basis to contain a list of the goals and operational action items which have been completed, or that have been eliminated from any further consideration.

SWOTT

The Strategic Planning process continues to be a guiding force during 2009. Legislative successes, coupled with our Strategic Planning efforts, continue to move the fire department forward in many areas. The SLP team has committed to going out for a Bond in 2010 if we have a stable economy.

In addition, the “Top 10” list was updated in February of 2009 to ensure that the ten (10) most important objectives, as determined by the Strategic Planning Team itself, would be given the primary focus during the balance of 2009 and heading into 2010.

Finally, a SWOTT (Strengths, Weaknesses, Opportunities, Threats and Trends) Analysis was conducted by the Strategic Planning Team in February of 2009, with the focus on the years 2009 through 2013. The following represents the results of the SWOTT analysis, followed by the updated “Top 10 List for 2009/2010”.

Strengths

- Planning
- Community support
- Stable funding
- Capital reserve
- Personnel
- Team work
- Shared vision
- Leadership
- Keeping our word and commitment
- Bargain for our tax rate
- Transparency to public
- Class 2
- JATC
- Relationship with FWPD and DMPD
- Relationships with water districts, etc.
- Health Wellness Program
- Emergency Management progress
- RCW 52.33 efforts
- Water Supply

Weaknesses

- Capital Replacement Schedule
- High L & I Rate
- Changing of upper management
- Response times in some areas
- Lack of staffed aerial
- Lack of fire flow in Water District #54
- Aging facilities

- Communications
- Private ambulance handling transports
- Not communicating well enough with diverse community
- Lack of crew continuity
- Need to be better prepared for a disaster
- staffing generally

Opportunities

- Alternate funding
- EMS Levy (.20 cents per \$1,000)
- Patient Transports
- Bond Issue
- Accreditation
- Stronger pension program
- Make sure our citizens know we are financially strong
- Class 1 in FW or Class 2 in Des Moines
- Changing of upper management
- Residential sprinklers
- Response times in some areas
- Fire based ALS
- Communications
- Work with EMS to control EMS call growth
- Improve ICS within PD

Threats

- Funding at 1% per year
- EMS Levy
- Impact on LEOFF2
- The Economy
 - Non payment of taxes
 - Reduced for us
 - Reduced revenues in future
- Move calls for service
- Lack of ICS within Police Departments

Trends

- Benefit charge or excess levy
- Aging personnel
- Mergers, consolidations, annexations & RFA
- Changing of upper management
- Taller buildings
- Increased work load
- Increased educational opportunities
- Increase in violence and high risk calls
- Gang issues

- Aging population and more calls for social medicine incidents
- Handling more “police type” services
- Increased dependency on technology

After much discussion on the SWOTT (Strengths, Weaknesses, Opportunities, Threats and Trends) Analysis we came up with another list of items, Start, Stop and Continue, this was conducted by the Strategic Planning Team in February of 2009. The following represents the results of the SSC analysis:

Start, Stop Continue

Start

- Bond education “community”
- Start planning for next EMS Levy
- Start using plain English on inspection letters
- SAFER Grant funding
- Coordination of all Grants through Finance
- SharePoint

Stop

- Loan ranger approach to Grant funding

Continue

- Be involved in Olympia
- Involvement in community organizations
- Develop a clear line of succession for future leaders
- Evaluation of aerial operations
- Engage Des Moines City Council on Emergency Management & other issues
- Evaluation of statics & strategizing
- Press release related to former CFO
- Ability by our new financials checks and balances
- Emphasis on health and wellness
- Our planning for a 2010 bond issue (March 2010)
- Our efforts on the level of service

Top 10 List for 2009/2010

The following objectives have been identified by the Strategic Leadership Planning Team as the “Top Ten” issues of significance for the balance of 2009 and heading into 2010. These are the key items from our Strategic Leadership Plan that our team, and our other department personnel, should work on with the goal of bringing each to resolution within the next year or so. **The team leaders are identified together with team members, which can be added to from the ranks of our very talented employee base.**

Human Resource Objectives:

- 1) **HR Action Step #2: The Administration and Labor should work together in analyzing alternative health care options for all personnel.**

Note: This was initiated in 2008 with the work on an HRA. To be followed up on in 2009 and beyond.

Team Leaders: Chief Church
HR Administrator Mary Stevens
Union President/Lt. Ryan Herrera
CFO David Lawson

Team Members: Commissioner Gates
Union Vice President/Lt. Scott Ervin
FF Blake Heinze

- 2) **HR Action Step #4: A process for succession planning, individualized counseling and mentoring shall be developed to enhance the development of our personnel. This shall include:**
 - A system to track the ongoing educational goals, and education itself, of our personnel related to their professional development with an inherent goal of providing the employees assistance with their ongoing development.

Team Leaders: Chief Church
A/C Ed Plumlee
Executive Assistant Lauri Perry
HR Administrator Mary Stevens

Team Members: PEO Donna Conner
Yvette Dominguez

Integrated Operations Objectives:

- 3) **Operations Action Step #2: #2: A team shall be developed to begin evaluating response data to determine compliance/non-compliance**

with the requirements of NFPA 1710. The team shall make recommendations to the Administration and Labor related to NFPA 1710 objectives not being met, if any.

- A full staffing analysis shall be conducted related to current and future placement of personnel and apparatus to meet the response goals as defined by the department.
- The Deputy Chief of Support Services, the HR Manager, the Assistant Chief of Operations and the Fire Chief/Administrator shall initiate the self-assessment process for accreditation as a high priority.

Team Leaders: A/C Ed Plumlee
D/C Mike Knorr
FF Shane Smith

Team Members: D/C Steve Trackwell
Captain Kevin Body
Lt. Gregg Bordner
Union Treasurer/Lt. Joel Barrett
D/C Gordie Olson
FF Mike D. Lawson

4) **Operations Action Step #4: #4:** An “aerial committee” shall be appointed to work on a recommendation for the department’s future needs after considering all options related to aerial operations.

- The final recommendation will be coordinated with all bond issue work in 2009/2010.
- The committee shall consider aerials, quints, and other applicable apparatus to meet response needs.

Team Leaders: A/C Ed Plumlee
D/C Gordie Olson
B/C Chuck Kahler
B/C Bob Stinnett
B/C Rick Chaney

Team Members: Lt. Pat Soper
FF Shane Smith
Captain Alex Charoni
FF Mike D. Lawson
Lt. Roy Smith
Steve Denton
Lt. Chris Murphy
Lt. Jeff Bellinghausen
FF Joe Eliassen
FF Chris Andersen

Leadership Objectives

- 5) **Leadership Action Step #2:** An “Operations Career Development” program shall be developed and implemented that addresses pre-officer training, pre and post-promotion readiness and mentoring, and ongoing education for all leadership positions. This program should be linked into the Officer Development program.
- The plan would outline an individual’s career path and career objectives.

Team Leaders: A/C Ed Plumlee
D/C Vic Pennington
B/C Rick Chaney

Team Members: HR Administrator Mary Stevens
B/C Chuck Kahler
B/C Bob Stinnett
Captain Alex Charoni
Lt. Jeff Bellinghausen
Captain Dave Mataftin
Union President/Lt. Ryan Herrera
Captain Kevin Crossen
Lt. Roy Smith
FF Anthony John
FF Todd Williams

- 6) **Leadership Action Step #4:** The Administration and Labor shall finalize and implement a communications model to improve the sharing of information within the department (i.e. numbered memos, written policies, newsletters, and all forms of communication shall be revisited). An improved and enhanced form of communication, using Tandberg and the addition of Sharepoint with the possibility of being able to use Tandberg to be in contact other departments to share training and other information.

Team Leaders: IT Director Joe Ganem
Captain Kevin Crossen
Union President/Lt. Ryan Herrera

Team Members: Executive Assistant Lauri Perry
Mitchell Lee

Community Objectives

- 7) **Community Action Step #6:** The fire district shall work towards the adoption of a residential sprinkler ordinance in the City of Federal

Way and the City of Des Moines. The goal will be to coordinate efforts in 2009 and 2010 with the Washington Fire Chiefs, the Washington Fire Commissioners Association, the Washington State Council of Fire Fighters, the NFPA and the Sprinkler Coalition in this united effort.

Team Leaders: Chief Church
D/C Ron Biesold
Prevention Division

Team Members:

- 8) **Community Action Step #7:** The fire district shall enhance our current public outreach efforts with an emphasis on utilizing local statistics, local partnerships, and our vast array of resources to design programs with a goal of reducing fires and injuries in our service area, and thus improving the overall quality of life for our citizens. An emphasis in 2009/2010 shall be on providing smoke detectors and smoke detector batteries to our citizens.

Team Leaders: A/C Ed Plumlee
D/C Gordon Olson
D/C Ron Biesold

Team Members: Public Education

Finance Objectives

- 9) **Financial Action Step #4: #4:** The fire district's Board of Fire Commissioners, Administrative Team, and Strategic Leadership Planning Team shall plan for and develop the financial plan for a potential March of 2010 bond issue by no later than August of 2009.

This shall include the following key dates:

- **February-August of 2009:** Complete all bond issue work related to costs, projects to be funded, etc.
- **September/October of 2009:** Presentation to full Board of Fire Commissioners for augmentation as required.
- **November/December of 2009:** Final approval by the Board of Fire Commissioners and filing by resolution with King County Elections.
- **January/February/March of 2010:** The informational campaign related to the bond issue.
- **March of 2010:** The ballot issue itself requiring a 60% yes vote with a 40% validation from the prior General Election in order to validate and pass.

Team Leaders: Chief Church
D/C Mike Knorr

Team Members: A/C Ed Plumlee
CFO David Lawson
D/C Steve Trackwell
Commissioner Gates
Commissioner Fossos
Commissioner Hershey
Executive Assistant Lauri Perry
Union President/Lt. Ryan Herrera
Union Treasurer/Lt. Joel Barrett
PEO Kendra Kay

- 10) **Finance Action Step #3: The Finance Division and Administrative Team shall analyze the accounting system in use by the fire district to determine if it meets our short and long term needs, or if an alternate system better serves our overall objectives. This analysis shall be completed by mid-2009.**

Team Leaders: CFO David Lawson
Finance Division

Team Members: IT Director Joe Ganem
HR Administrator Mary Stevens

SOUTH KING FIRE & RESCUE

MASTER STRATEGIC
LEADERSHIP TEAM
WORK PRODUCT
2010

This section will be updated on an annual basis to contain a list of the goals and operational action items which have been completed, or that have been eliminated from any further consideration.

SOUTH KING FIRE & RESCUE

MASTER STRATEGIC LEADERSHIP TEAM WORK PRODUCT 2011

This section will be updated on an annual basis to contain a list of the goals and operational action items which have been completed, or that have been eliminated from any further consideration.

SOUTH KING FIRE & RESCUE

MASTER STRATEGIC LEADERSHIP TEAM WORK PRODUCT 2012

This section will be updated on an annual basis to contain a list of the goals and operational action items which have been completed, or that have been eliminated from any further consideration.

SOUTH KING FIRE & RESCUE

MASTER STRATEGIC LEADERSHIP TEAM WORK PRODUCT 2013

This section will be updated on an annual basis to contain a list of the goals and operational action items which have been completed, or that have been eliminated from any further consideration.